

Horizontal Multi-joint Industrial Robot Manual

V1.0.0

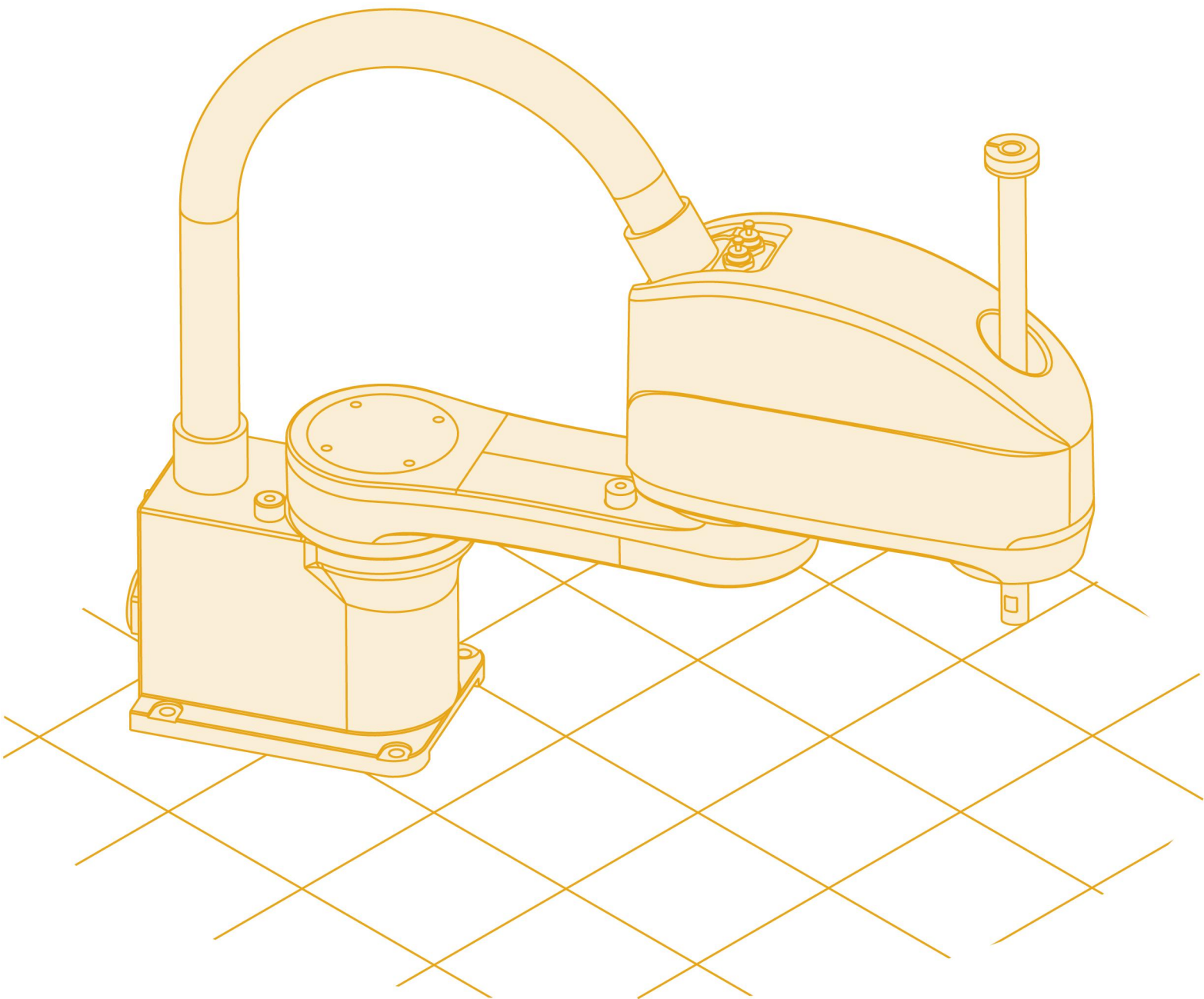

Foreword

About this manual

This manual is for technicians to install, use, and use the industrial robot quickly, correctly, and safely, to be familiar with the relevant precautions, and to perform regular routine maintenance work on the manipulator.

Prerequisites

Before operating the robot, be sure to read the relevant safety instructions and operation instructions of the product carefully. Users must understand the safety knowledge and basic operation knowledge before using the robot.

Please read the following documents when necessary:

- “inCube2S Control Cabinet Manual”
- “SCARA type teach pendant operation manual”
- “ARL Programming Manual”
- “ Horizontal Multi-joint Industrial Robot System Quick Start Manual”



Target groups



- Operators
- Product technicians
- Technical service personnel
- Robot teachers

Meaning of common signs

The signs and their meanings in this manual are detailed in Table 1.

Table 1 Signs used in this manual

Sign	Meaning
 Danger	Failure to follow the instructions may result in an accident causing the severe or fatal injury or the great losses of property.
 Warning	Failure to follow the instructions may result in an accident causing the severe or fatal injury or the great losses of property.

Sign	Meaning
 Caution	Prompt for the environmental conditions and important things or shortcuts you shall pay attention to
 Prompt	Prompt for additional literature and instructions for additional information or more detailed operating instructions

Manual description

The contents of this manual are subject to supplementation and modification. Please visit "Download Center" on the website regularly to obtain the latest version of this manual in a timely manner.

Website URL: <http://ligentrobot.com/>

Revision history

The revision history contains the instructions for each document update. The latest version of the document contains updates to all previous versions of the document.

Table 2 Signs used in this manual

Version	Publication date	Modification description
V1.0.0	2020.06.30	1st official publication

Manual Number and Version

The manual-related information is shown in Table 3.

Table 3 Document-related information

Document name	" Horizontal Multi-Joint Industrial Robot Manual"
Document number	UM-P05310000029-001
Document version	V1.0.0

Declaration of applicable with product standards

The requirements for industrial robot system design are detailed in Table 4.

Table 4 Declaration of applicable safety standards

Standard	Description	Version
2006/42/EC	Machinery directive : Machinery directive 2006/42/EC (new version) issued by European Parliament and Council on May 17, 2006 to modify 95/16/EC	2006
2014/30/EU	Electromagnetic compatibility directive: 2014/30/EU directive issued by European Parliament and Council on February 26, 2014 to balance the electromagnetic compatibility regulations of member states	2014
2014/68/EU	Pressure facility directive: Electromagnetic compatibility directive: 2014/68/EU directive issued by European Parliament and Council on May 15, 2014 to balance the pressure facility regulations of member states (It is only suitable for the robot with hydraulic balance weight)	2014
ISO 13850	Safety of machinery: Emergency stop function - Principles for design	2015
ISO 13849-1	Safety of machinery: Safety-related parts of control systems - Part 1: General principles for design	2015
ISO 12100	Safety of machinery: General principles for design - Risk assessment and risk reduction	2010
ISO 10218-1	Robots and robotic devices - Safety requirements for industrial robots : Part 1: Robots (Prompt: Information is consistent with ANSI/RIAR.15.06-2012, Part 1)	2011
61000-6-2	Electromagnetic compatibility (EMC): Part 6-2: Generic standards - Immunity for industrial environments	2005
61000-6-4 + A1	Electromagnetic compatibility (EMC): Part 6-4: Generic standards - Emission standard for industrial environments	2011
60204-1 + A1	Safety of machinery: Electrical equipment of machines - Part 1: General requirements	2009
IEC 60529	IP rating provided by enclosures (IP Code): This standard applies to the IP rating for the electrical equipment with enclosures and the rated voltage exceeding 72.5kv.	2001

General safety description

Thank you for purchasing our manipulator. This description is required for the safe use of the manipulator. before using the operator, please read the manual carefully and use the manipulator correctly on the premise of understanding it.

For the detailed functions of the manipulator, please fully understand its specifications through the relevant instructions.

Safety considerations

In general, the manipulator cannot be operated by a single operation, and only install the end effector, and the frame functions as the peripheral equipment and the system to perform the operation.

When considering its security, the manipulator should not be considered independently, but should be considered in the system environment.

WARNING, CAUTION AND PROMPTS.

This specification includes matters needing attention to ensure the personal safety of operators and prevent damage to operators. According to their safety importance, they are described as "warning" and "caution" in this paper, and the supplementary instructions are described as "prompts".

Before using the operator, the user must read these "warnings ", "cautions" and "prompts ".



In the case of an incorrect operation, it is possible to cause death or serious injury to the operator or other operator.



If the operation is wrong, it may cause the operator or other operator to slightly injure or damage the equipment.

General considerations



Operators who use the operator should wear the safety appliances shown below before carrying out their work.

- Work clothes suitable for the job content
- Safety shoes
- Safety helmet



Prompt

Personnel who carry out programming and maintenance operations must receive appropriate training through the relevant training of the company.

Considerations during installation



Warning

- When handling and installing the machines, they must be carried out correctly according to the method shown in our manual. If the operation is carried out in the wrong way, it is possible that the operator will be killed or injured due to the overturning of the operator.
- When using the operator for the first time after installation, be sure to do so at a low speed, and then gradually accelerate the speed and confirm that there are any anomalies.

Matters needing attention in operation



Warning

- When using the operator, be sure to make sure there are no personnel in the safety fence before carrying out the operation. At the same time, check to see if there is a potential danger, and when it is confirmed that there is a potential danger, be sure to eliminate the danger before carrying out the operation.
- When using the instruction device, because there may be errors in the operation of wearing gloves, it is important to take off the gloves before carrying out the work.



Prompt

Information such as programs and system variables can be stored in storage media such as memory cards. In order to prevent data loss caused by unexpected accidents, it is recommended that users back up data regularly.

Contents

Foreword	I
General safety description	V
Contents	i
1. Product specification	1
1.1. General functions and intended applications	1
1.2. Environmental conditions and working and storage limitations	1
1.2.1. <i>Environmental requirements</i>	1
1.2.2. <i>Environmental conditions for long-term storage</i>	1
1.2.3. <i>Precautions for storage</i>	2
1.3. Basic specifications	2
2. Robot system introduction	5
2.1. Introduction to industrial robots	5
2.2. Basic configuration of manipulator	5
2.3. Product label and meaning	6
3. Preparation before use	9
3.1. Safety precautions before use	9
3.2. Product unpacking	10
3.2.1. <i>Unpacking method</i>	10
3.2.2. <i>Safe disposal of packaging materials</i>	11
3.2.3. <i>Disposal of waste materials</i>	11
3.3. Preparation before installation	11
3.3.1. <i>Installation Precautions</i>	11
3.3.2. <i>Installation tools and required connectors</i>	12
3.4. Installation and assembly	12
3.4.1. <i>Technical specifications</i>	12
3.4.2. <i>Fixed way</i>	12
4. Electrical interface	15
4.1. Manipulator electrical interface type	15
4.2. Heavy-duty line interface on the manipulator side	16
4.3. Heavy-duty line interface on the cabinet side	18
4.4. User I/O interface of manipulator	20
4.5. Power cable interface	20
5. Job description	23
5.1. Safety precautions	23
5.2. Safe operation	24
5.2.1. <i>LED indicator</i>	24
5.2.2. <i>Structural dimensions</i>	24
5.2.3. <i>Working range of each axis</i>	25
5.2.4. <i>Mechanical limit</i>	26
5.2.5. <i>Stop mode</i>	27
5.3. Calibration	28
5.3.1. <i>When is calibration required</i>	28
5.3.2. <i>Calibration position of each axis</i>	28
5.3.3. <i>Movement direction of each axis</i>	30
5.3.4. <i>Speed of each axis</i>	31
5.4. Flange size	31
5.5. Load installation	32
6. Transportation and handling	35
6.1. Transport attitude	35
6.2. Transport dimensions	36
6.3. Handling method	38
7. Preventive maintenance	39

7.1.	Safety protection measures	39
7.2.	Daily maintenance	40
7.3.	First maintenance	40
7.4.	Regular maintenance	42
7.5.	Grease filling	43
8.	Project maintenance process	45
8.1.	Cleaning the manipulator	45
8.2.	Check and repSOT cables	45
8.3.	Replacing the battery	47
8.4.	Replace timing belt	49
9.	Fault finding, diagnosis and repSOT	59
Appendix A	 type manipulator regular maintenance table	67
Appendix B	Table of screw strength and tightening torque (Nm)	71

1. Product specification

1.1. General functions and intended applications

Industrial robot systems are used to move tools and devices, or process and transport workpieces or products. It is allowed to be used only in accordance with the specified climatic and environmental conditions. For specific storage conditions and working environment requirements, please refer to **Chapter 1.2.**

All non-compliant use is illegal and prohibited. These non-compliant uses include:

- Use in environments where there is a danger of explosion.
- Use outside the allowed motion range.
- Transporting people or animals.
- Used as a climbing aid.

 Caution	Changing the structure of the robot, such as drilling holes, can cause component damage. This is regarded as improper use and will result in loss of warranty and claim eligibility.
--	--

1.2. Environmental conditions and working and storage limitations

1.2.1. Environmental requirements

See Table 1- 1 for the operating environment requirements of manipulator.

Table 1- 1 Environmental requirements for equipment manipulator

Temperature	Lowest temperature	0℃
	Maximum temperature	40℃
Humidity	The operating environment requirements of the manipulator do not exceed the humidity level not higher than 95% as specified in the document "IEC 60721-3-3-2002 Classification of environmental conditions".	
Altitude	The altitude of the normal operating environment of the manipulator should not exceed 1000 meters. In the height range of 1000 meters-4000 meters, the manipulator should be reduced in rated power to use	
Shock resistance	The robot manipulator should be used in an environment without vibration as much as possible. The environmental vibration limit frequency is 5Hz~55Hz, and the amplitude does not exceed 0.15mm.	
Special environmental requirements	The manipulator is prohibited to use in flammable, explosive and corrosive environment.	

1.2.2. Environmental conditions for long-term storage

The manipulator should be placed in a cool place protected from direct sunlight and waterproof during long-term storage. The specific environmental requirements are shown in Table 1- 2 below.

Table 1- 2 Manipulator long-term storage environmental conditions

Parameter	Value
Minimum ambient temperature	-25℃
Maximum ambient temperature	55℃
Maximum ambient temperature (storage time less than 24h)	70℃
Maximum ambient humidity	Less than 95% at constant temperature, no condensation
Maximum vibration conditions	Frequency 5~55Hz, amplitude 0.15mm

1.2.3. Precautions for storage

In addition to the content of *Chapter 1.2.1* of this manual, the long-term storage of the manipulator should also pay attention to the following items:

- Before long-term storage of the manipulator, the posture should be in the transport posture, placed on a horizontal surface and fixed, see *Chapter 3.3* of this manual for details.
- When the manipulator is not used for a long time, all power supply should be cut off.
- Use an outer protective cover such as paper or wooden packaging box to protect the manipulator from external light to avoid long-term exposure to the manipulator or exposure to water, oil, corrosive liquids, etc.
- The surface of the manipulator should be cleaned regularly, such as dust removal and decontamination. The specific cleaning cycle depends on the storage environment of the manipulator.
- When the storage period ends and the manipulator is put back into use, the manipulator must be inspected in accordance with *Chapter 3.3.1* of this manual.

1.3. Basic specifications

The basic specifications of robot are shown in Table 1- 3.

Table 1- 3 Basic specifications of robot

Coordinate form		Horizontal multiple joint robot
Number of control axes		4 axes(J1,J2,J3,J4)
Action range (upper/lower limit)	J1	-136° ~136°
	J2	-141° ~141°
	J3	-150 ~ 0mm
	J4	-360° ~360°
Maximum range of motion		400mm
Maximum operating speed	J1	600° /s
	J2	600° /s
	J3	1100mm/s
	J4	2600° /s
Handling weight		1kg(Rated)/3kg(Maximum)

Coordinate form	Horizontal multiple joint robot	
Drive method	Use AC servo motor for electric servo drive	
Repeatability	Axis1+Axis2	+/-0.010mm
	Axis3	+/-0.010mm
	Axis4	+/- 0.01 deg
Robot quality	14kg	
Noise	70dB	
IP protection level	IP40	
Installation conditions	Ambient temperature: 0~40℃ Humidity: within 95% at constant temperature, no condensation Allowable height: below 1000m above sea level There should be no corrosive, flammable, explosive gases	

2. Robot system introduction

2.1. Introduction to industrial robots

The industrial robot system is mainly composed of three basic parts: industrial robot manipulator, control cabinet and teach pendant:

- **Manipulator** refers to the mechanism used to grab or move objects (tools or workpieces) in the robot system, also known as the robot body. This manipulator is a horizontal multi-joint industrial robot, including a linear axis and three rotary axes.
- **Control cabinet** is installed with the electrical equipment needed to control the robot, and provides a connection interface with the robot manipulator and other external equipment.
- **Teach pendant** is connected to the main control system of the control cabinet, and is used to control the manual/automatic operation of the robot, record the running track, display playback or record the teaching point and program according to the teaching point.

The structure of horizontal multi-joint industrial robot system is shown in Figure 2- 1.

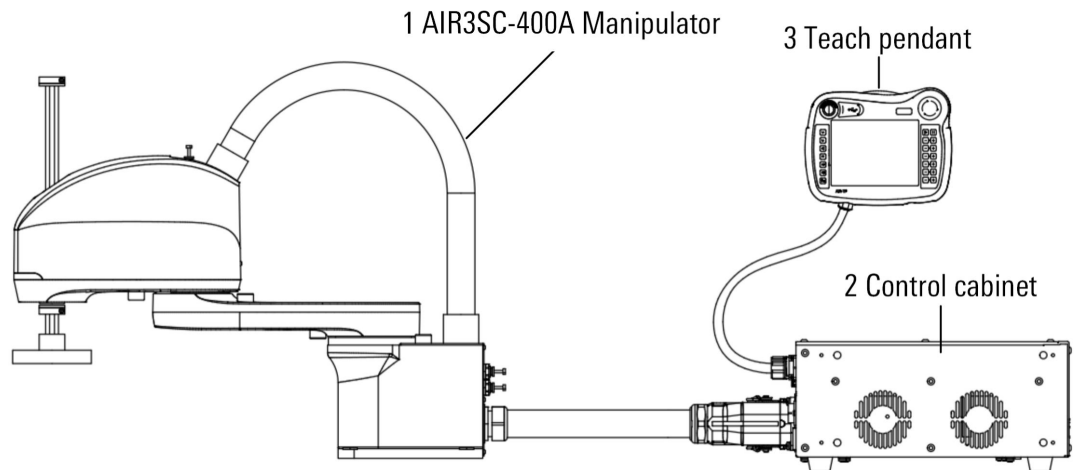

Figure 2- 1 Composition of industrial robot system

2.2. Basic configuration of manipulator

The names of type manipulator and each part of it are shown in Figure 2- 2.

For the basic specifications of the manipulator, please refer to **Chapter 1.3** of this manual. For the dimensions and working range of each axis, please refer to **Chapter 5.2.1** and **5.2.3** of this manual.

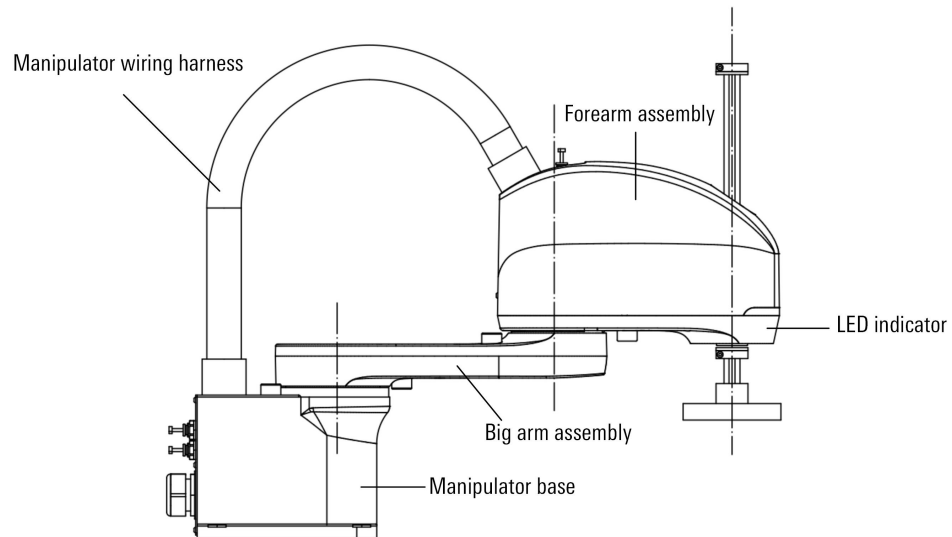



Figure 2-2 robot body and its parts

2.3. Product label and meaning

Operator nameplate

The nameplate of the manipulator is attached to the base. The nameplate contains the corresponding model, product number, weight, serial number, production date and other information of the corresponding product (refer to Figure 2-3). The nameplate information is subject to the actual factory shipment. Refer to Figure 2-4 for the specific location of the nameplate.

型号/Type	AIR3SC-400
产品号/Product No.	R010A20107
序列号/Serial No.	P05310000029-20XXXX0001
生产日期/Date	2021-XX-XX
重量/Weight	14kg
最大负载/Payload	3kg
运动半径/Range	400mm
电机功率/ Motor Power	X:200W Y:100W Z:100W R:100W



S N : P 0 5 3 1 0 0 0 0 0 2 9 - 2 0 X X X X 0 0 0 1

Figure 2-3 Schematic diagram of the nameplate of the manipulator

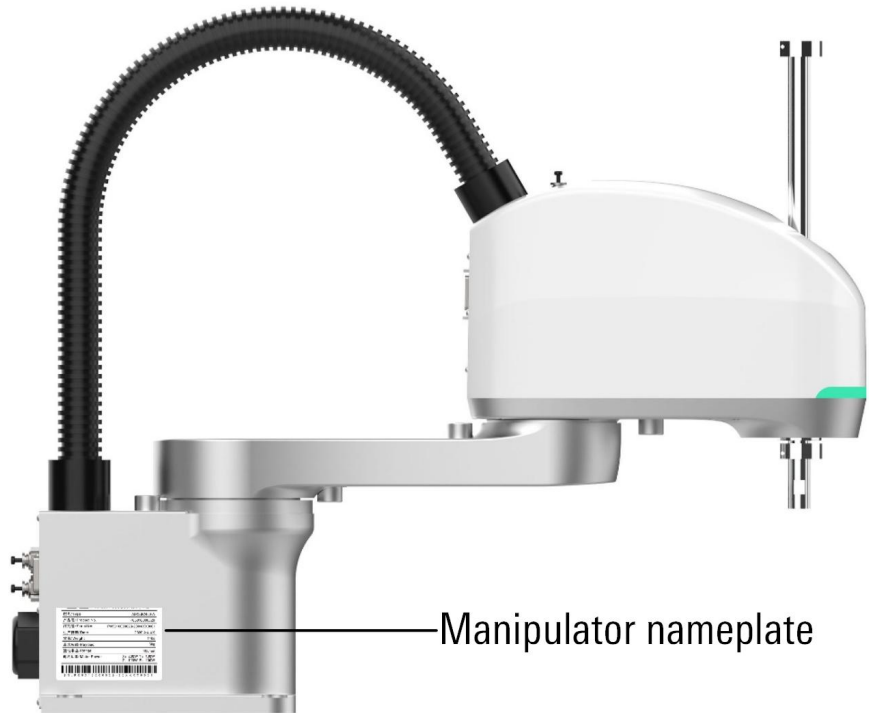

Figure 2- 4 Schematic diagram of the nameplate position of the manipulator

Hazard warning label

A “danger warning label” is attached to a conspicuous position on the back of the manipulator arm (as shown in Figure 2- 5 and Figure 2- 6).



Figure 2- 5 Hazard warning label



Figure 2-6 manipulator hazard warning label location diagram

3. Preparation before use

3.1. Safety precautions before use

Before operating the manipulator, peripheral equipment and manipulator system, the safety precautions of the operator and the system must be fully studied.

Operator definition

The operators of the manipulator are mainly divided into three types: operators, teachers, and maintenance engineers.

The conditions that these three operators need to meet are described as follows:

Operators

- ON/OFF operation of the power supply of the manipulator;
- Start the manipulator program through the operation panel;

Teachers

- Possess the function of operator;

Maintenance engineers

- Possess the function of teacher;
- Can carry out maintenance (repSOT, adjustment, replacement, etc.) operation of the manipulator.

Operator safety

When operating, programming, and maintaining the manipulator, operators, teachers, and maintenance engineers must pay attention to safety, and at least wear the following items for work:

- Work clothes suitable for the content of the job
- Safety shoes
- Helmet

When using an automatic system, you must try to ensure the safety of the operators. It is very dangerous to enter the operating range of the manipulator. Measures should be taken to prevent the operators from entering the operating range of the manipulator.

The general precautions are listed below, please take appropriate measures to ensure the safety of the operators:

- The operation personnel running the manipulator system shall receive the training from the company and pass the relevant assessment.
- While the equipment is running, even if the manipulator seems to have stopped, the manipulator is possibly waiting for the start signal and is about to act. The manipulator shall be regarded as operating at this state. To ensure the safety of operation personnel, it is necessary to confirm that the manipulator is in the operating state via the audible and visual alarms such as the warning lamp
- Be sure to set the safety barrier and safety door around the system so that the operation personnel cannot enter the safety barrier without opening the safety door. The interlock switch, safety pin, etc. shall be set on the safety door so that when the operator opens the safety door, the manipulator will stop.
- Peripheral equipment shall be electrically grounded.
- The peripheral equipment shall be set outside the range of manipulator if possible.
- The range of manipulator shall be clearly marked with the lines on the floor to make the operator understand the range of manipulator including the mechanical arm and other tools.

- A proximity switch or photoelectric switch shall be installed on the floor so that when the operation personnel are about to enter the range of manipulator, the audible and visual alarms such as the buzzer are issued to stop the manipulator, thereby ensuring the safety of operation personnel.
- A lock shall be set if possible to make sure that the manipulator power cannot be turned on except by the operation personnel responsible for the operation.
- Always disconnect the manipulator power when performing the individual commissioning of peripheral equipment.

Safety of Operators

The emergency stop button should be set within the reach of the operators.



Prompt

Manipulator controller is designed to be connected to an external emergency stop button. With this connection, the manipulator will stop when the external emergency stop button is pressed.

Safety of Teachers

In the teaching operation of the manipulator, in some cases, it is necessary to enter the working range of the manipulator, in this case, special attention should be paid to safety:

- If you do not need to enter the manipulator range, be sure to operate outside the manipulator range.
- Before proceeding with the teaching, verify that the manipulator or peripheral equipment is in a safe state.
- If it is inevitable to enter the range of manipulator to conduct the teaching, first confirm the positions and states of safety devices (such as the emergency stop button, emergency automatic stop switch of teach pendant, etc.).
- Teachers shall pay special attention to make other people away from the range of manipulator.
- Before starting the manipulator, first confirm that there is no people and no abnormality in the range of manipulator.
- After the teaching is over, be sure to perform the test run following the steps below:
 - Step1. At low speed, execute at least one cycle intermittently to confirm no abnormality.
 - Step2. At low speed, execute at least one cycle continuously to confirm no abnormality
 - Step3. At intermediate speed, execute at least one cycle continuously to confirm no abnormality
 - Step4. At operating speed, execute at least one cycle continuously to confirm no abnormality
 - Step5. Execute the program in automatic operation mode.

3.2. Product unpacking

3.2.1. Unpacking method

As shown in Figure 3- 1, the packaging box of the manipulator is composed of a box body and a bottom bracket.

Operation process of unpacking:

- Step1. Remove the cover and take out the teaching pendant from above.
- Step2. Take out the middle partition, pay attention to prevent the control cabinet from falling.
- Step3. Take out the control cabinet from above and take out the built-in calcium chloride desiccant;
- Step4. Remove the box and use an allen wrench to loosen the four M5×30 hexagon socket head cap screws connecting the arm support sheet metal to the arm and the wooden base, and then unscrew the manipulator

and Four M8×50 hexagon socket head cap screws, washers and M8 hex nuts on the wooden bottom bracket can separate the operator from the bottom bracket. When the screws are loose when removing, please avoid tilting the operator and preventing the operator from tipping.

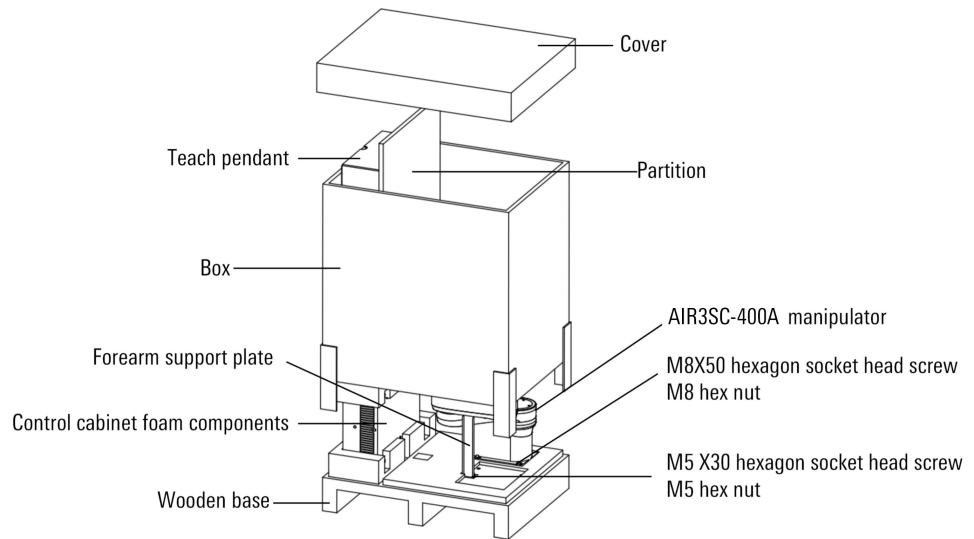

Figure 3- 1 Manipulator packaging diagram

3.2.2. Safe disposal of packaging materials

- In order to facilitate repacking, please properly save the carton, the bottom bracket and all the screws and nuts and other parts used in connection. Please keep the above materials in a dry and clean indoor place to prevent the materials from moisture, pressure, heat or close to fire source.
- If you don't need to keep the above materials, please handle them properly according to the relevant disposal methods of industrial waste.
- The packaging bag and calcium chloride desiccant can not be used again after unpacking, please handle it properly according to the relevant disposal methods of industrial waste.

3.2.3. Disposal of waste materials

Industrial robot system waste disposal must be carried out in accordance with the laws, regulations and standards of each country.

3.3. Preparation before installation

3.3.1. Installation Precautions

Before installing the manipulator, the items listed below must be strictly observed:

- Ensure that the installation staff must pass the relevant training of the company, and can only carry out installation work in compliance with international and local laws and regulations.
- After unpacking, make sure that the manipulator is not bumped and damaged.
- Ensure that the installation environment of the manipulator meets the requirements of *Chapter 1.2.1* of this manual.
- Ensure that the installation location of the manipulator can withstand the pressure or pulling force caused by the manipulator and its load (in the fixed position of the manipulator base, it can withstand an equivalent load of not less than 2kN and a torque of 600Nm in all directions).
- Before installation, the cable tie fixing the limit block needs to be removed

3.3.2. Installation tools and required connectors

The following tools may be required to install the manipulator (more tools may be required, depending on the specific installation method):

- An allen wrench
- Adjustable wrench
- Torque wrenches of different specifications, etc.

The connection parts that may be required for the installation of the manipulator are as follows (more connection parts may be required, depending on the specific installation):

- M8 screws of appropriate length and strength grade of 12.9 or several other size hexagon socket head cap screws.
- Several spring pads of $\Phi 8$ or other specifications.

3.4. Installation and assembly

3.4.1. Technical specifications

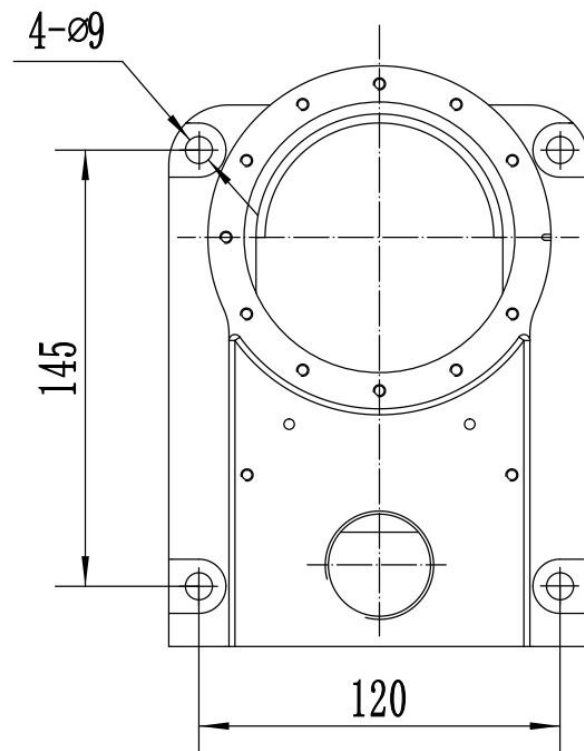
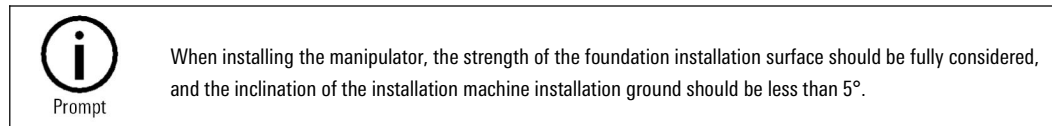



Figure 3-2 Base interface size of type manipulator

The base size of manipulator is shown in Figure 3-2. Among them, the hole of $\Phi 9$ can be used as a through hole for installing M8 screws.

3.4.2. Fixed way

The manipulator uses the "bracket fixation" fixation method.

 Prompt	The specific fixing method should be appropriately selected according to the environment used by the user.
---	--

The names and specifications of parts and components required for fixed manipulator are shown in Table 3- 1.

Table 3- 1 Manipulator fixing required parts

Parts name	Remarks
Manipulator fixing screws	4 M8x25 socket head cap screws (grade 12.9)
Robot fixing plate	Thickness 25mm, 1 piece (customer provided)

 Warning	The length of the fixing screw M8 of the manipulator must not be shorter than 25mm. If the length is too short, it may cause accidents such as poor fixing.
--	---

 Prompt	There must be no insulating material between the robot fixing plate and the mounting bracket and the manipulator. The "○" mark indicates that this part is needed. The bracket needs to be firmly installed on the ground, and the strength is required to ensure that the body works.
--	--

Fixing steps:

- Step1. In the handling attitude (refer to **Chapter 7**), transfer the manipulator to the top of the mounting bracket, and adjust the direction of the manipulator to make the base $\Phi 9$ through-hole holes aligned with the mounting bracket M8 threaded holes;
- Step2. Check whether the base is tightly attached to the surface of the mounting bracket without shaking. Use 4 M8x25 screws (strength grade 12.9) to fix the base of the manipulator on the bracket. Refer to Figure 3- 3.

 Prompt	The mounting surface of the bracket should meet certain flatness requirements, and the inclination of the mounting surface should be within 0.5mm.
---	--

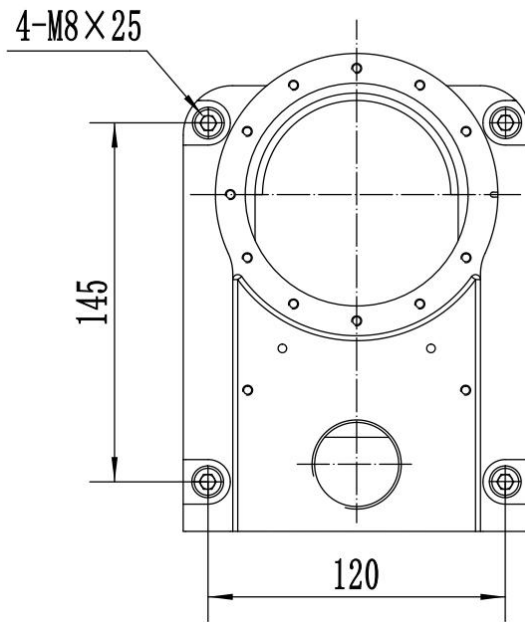

(a) Layout size

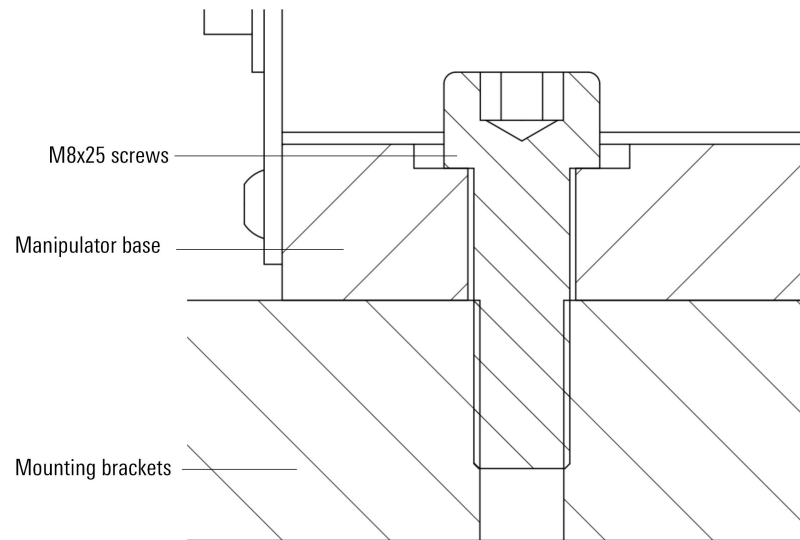

(b) Section view

Figure 3- 3 Schematic diagram of bracket fixing

4. Electrical interface

4.1. Manipulator electrical interface type

On the base of the manipulator, there are heavy-duty connectors, trachea joints and user IO input ports, and on the forearms there are brake buttons, user IO output ports and trachea joints. As shown in Figure 4- 1(a), the bottom of the base is a heavy-duty connector, and the upper left is two $\phi 6$ quick tracheal joints. After removing the blind plug, you can directly insert the $\phi 6$ trachea. The upper right is the user IO input port; The upper side is the user IO interface output port and the brake button; as shown in Figure 4- 1(b), there are two $\phi 6$ quick SOT pipe joints on the upper arm.

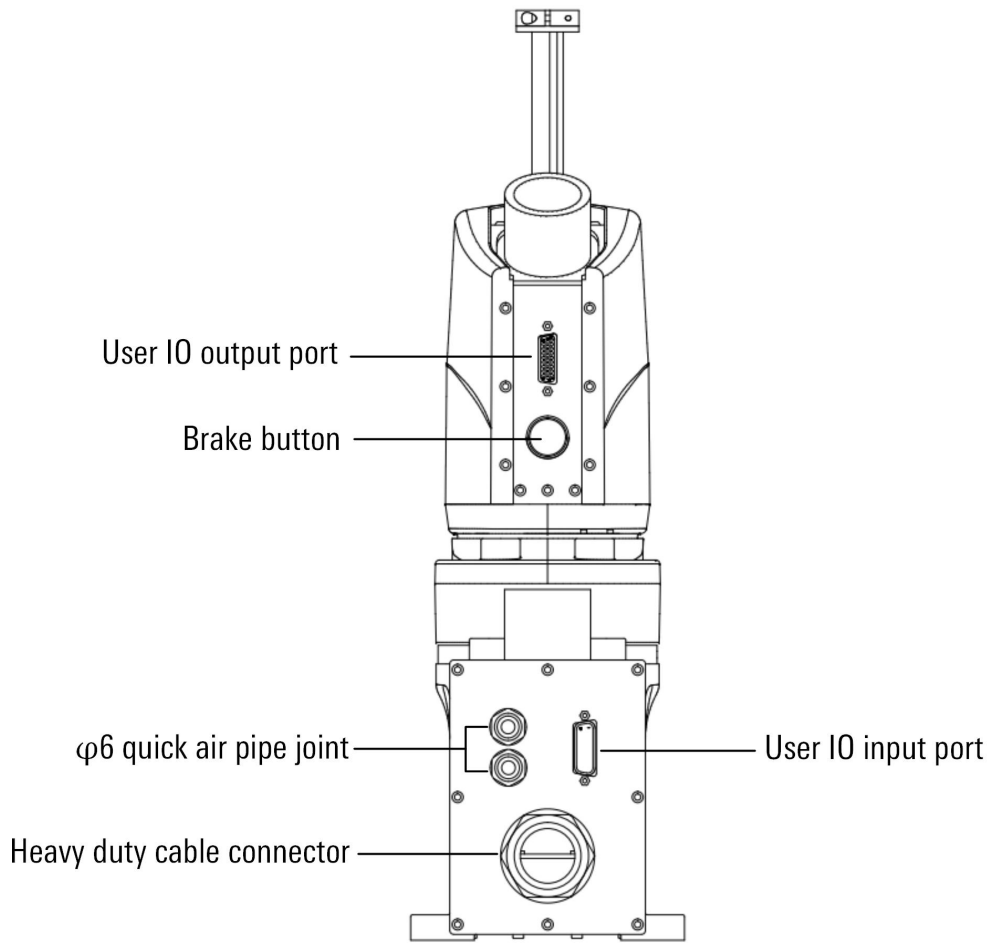

(a) Rear view

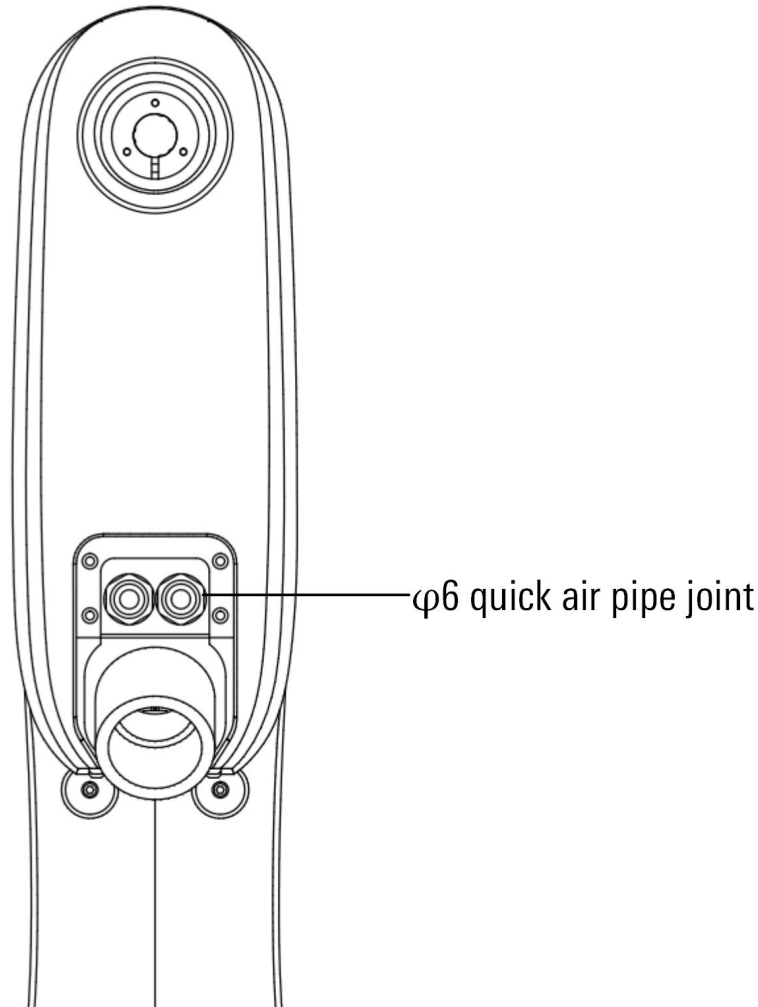

(b) Top view

Figure 4- 1 manipulator interface

Steps to manually release the brake:

- Step1. On the forearm sheet metal part, you can find the brake button, refer to Figure 4- 1(a).
- Step2. Connect the manipulator to the control cabinet, connect the control cabinet to the power supply, and turn on the control cabinet switch. For specific operations, see **Chapter 4.3** and **Chapter 4.5** of this manual.
- Step3. Press and hold the brake button to release the brake on axis 3 of the manipulator (refer to Figure 5- 8).



Caution

To prevent the output shaft from falling due to gravity when the brake is released, the base of the manipulator must be fixed.

When releasing the brake, it is necessary to drag the lower end of the output shaft to prevent the rapid drop and damage the manipulator.

The forearm IO interface Dsub26 of the forearm of the manipulator does not have a sealing structure, so it is necessary to prevent dust or liquid from entering the manipulator.

If you need to use the forearm IO interface, please select the corresponding option Dsub26.

4.2. Heavy-duty line interface on the manipulator side

The heavy-duty wire extends from the cable connector on the base of the manipulator, and the other end is connected to the control cabinet (see Figure 4- 2).

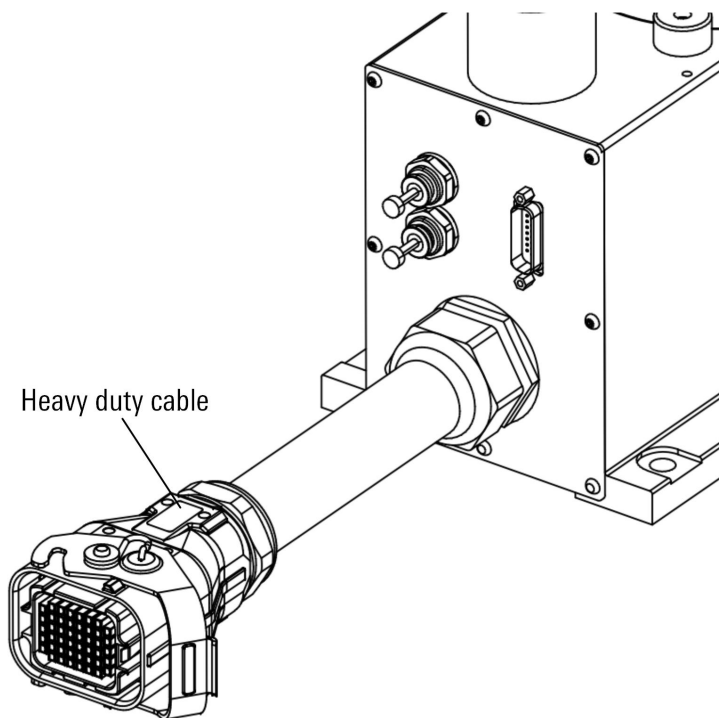

Figure 4- 2 Schematic diagram of heavy load line

The heavy-duty interface of manipulator is shown in Figure 4- 3.

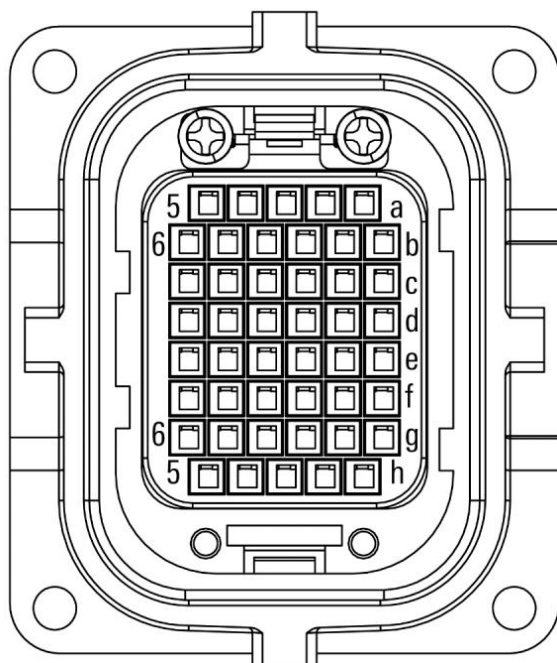

Figure 4- 3 Heavy-duty interface of manipulator

Port definition of power line & encoder line

The heavy load of type manipulator (power line & encoder line part) is shown in Table 4- 1.

Table 4- 1 Part of the interface definition of the heavy-duty manipulator (power line & encoder line)

Signal name	Axis number	Pin number	Signal name	Axis number	Pin number
Power line part					
U1	Axis 1	1f	U3	Axis 3	2f
V1	Axis 1	1g	V3	Axis 3	2g
W1	Axis 1	1h	W3	Axis 3	2h
PE	Axis 1	1e	PE	Axis 3	1e
U2	Axis 2	3f	U4	Axis 4	4f
V2	Axis 2	3g	V4	Axis 4	4g
W2	Axis 2	3h	W4	Axis 4	4h
PE	Axis 2	3e	PE	Axis 4	3e
Encoder line part					
J1_PS+	Axis 1	1a	J3_PS+	Axis 3	2a
J1_PS-	Axis 1	1b	J3_PS-	Axis 3	2b
J1_0V	Axis 1	1c	J3_0V	Axis 3	2c
J1_24V	Axis 1	1d	J3_24V	Axis 3	2d
J2_PS+	Axis 2	3a	J4_PS+	Axis 4	4a
J2_PS-	Axis 2	3b	J4_PS-	Axis 4	4b
J2_0V	Axis 2	3c	J1_0V	Axis 4	4c
J2_24V	Axis 2	3d	J1_24V	Axis 4	4d

Interface definition of brake and LED part

type manipulator heavy load interface definition (brake and LED part) is shown in Table 4- 2.

Table 4- 2 The definition of the heavy-duty interface of the manipulator (brake and LED part)

Signal name	Axis number	Pin number	Signal name	Axis number	Pin number
GND_24V_BR+	Axis 3	5g	LED_B#		5b
24V_BR_Out	Axis 3	6g	LED_R#		5c
GND	Axis 3	5f	LED_G#		6c
BR_MANUAL	Axis 3	6f	LED_24V		6b

4.3. Heavy-duty line interface on the cabinet side

As described in *Chapter 4.2* of this manual, the heavy-duty connector definition on the main body of the manipulator is connected to the control cabinet through a heavy-duty wire (refer to Figure 4 4). Both ends of the heavy-duty wire are used to connect the manipulator and the control. Cabinet, The heavy-duty line distinguishes between the manipulator end and the control cabinet end. The left side is the control cabinet end, and the right side needs to be fixed on the

manipulator end and cannot be removed. Please consult the manufacturer if you need to replace it (see Figure 4- 4).

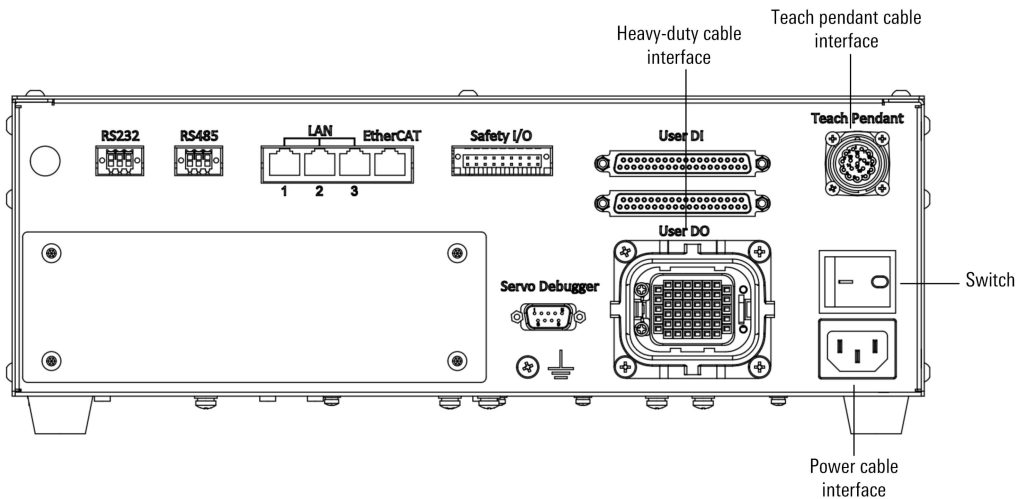

Figure 4- 4 Schematic diagram of control cabinet

Connection method:

Connect the control cabinet, insert one end of the heavy-duty line plug into the heavy-duty line connection port of the control cabinet (see Figure 4- 5, refer to Table 4- 1 and Table 4- 2 for interface definition), and fasten the lock.

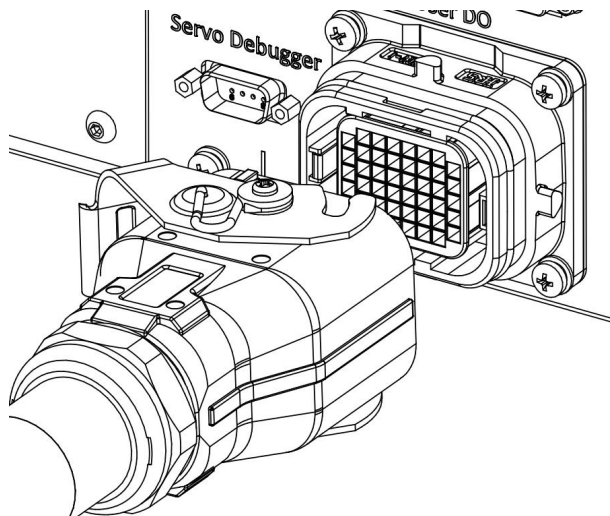

Figure 4- 5 Heavy-duty connector interface of the control cabinet

The length of the power encoder cable is 3m, and the size of the heavy-duty plug on the cabinet side is shown in Figure 4- 6 below.

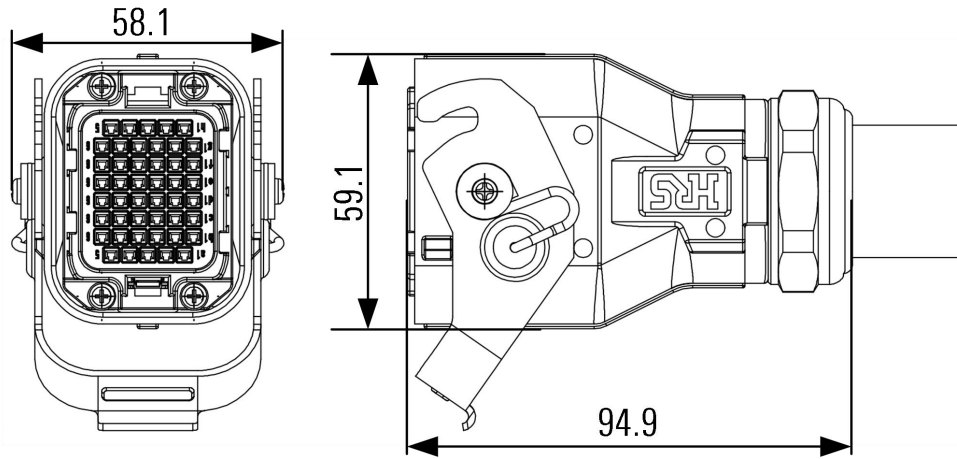

Figure 4- 6 The size of the heavy-duty plug on the cabinet side

4.4. User I/O interface of manipulator

The user I/O interface of manipulator is shown in Figure 4- 7 and Figure 4- 8. The I/O input interface is Dsub26 male, which is located on the rear cover of the base; the I/O output interface is Dsub26 female, which is located on the bellows sheet metal of the forearm assembly.

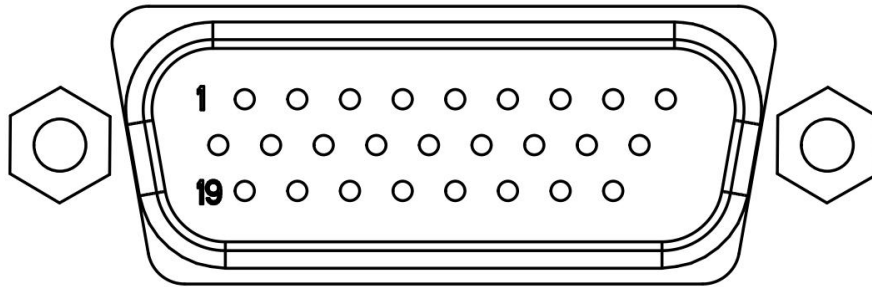

Figure 4- 7 I/O input interface on the base of manipulator

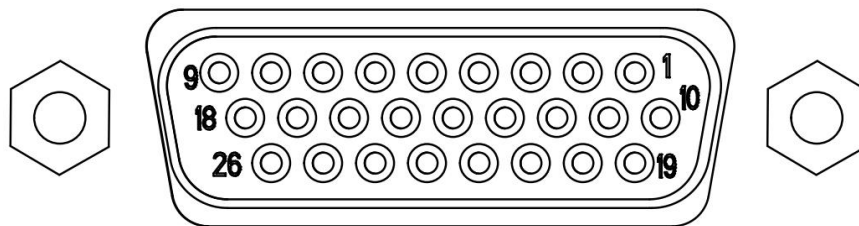

Figure 4- 8 I/O output interface on the forearm of manipulator



Prompt

The first 20 channels of the I/O interface are valid and defined by the customer. The connecting harness is optional. For details, please refer to the "Optional Accessories Installation Manual" of our company.

4.5. Power cable interface

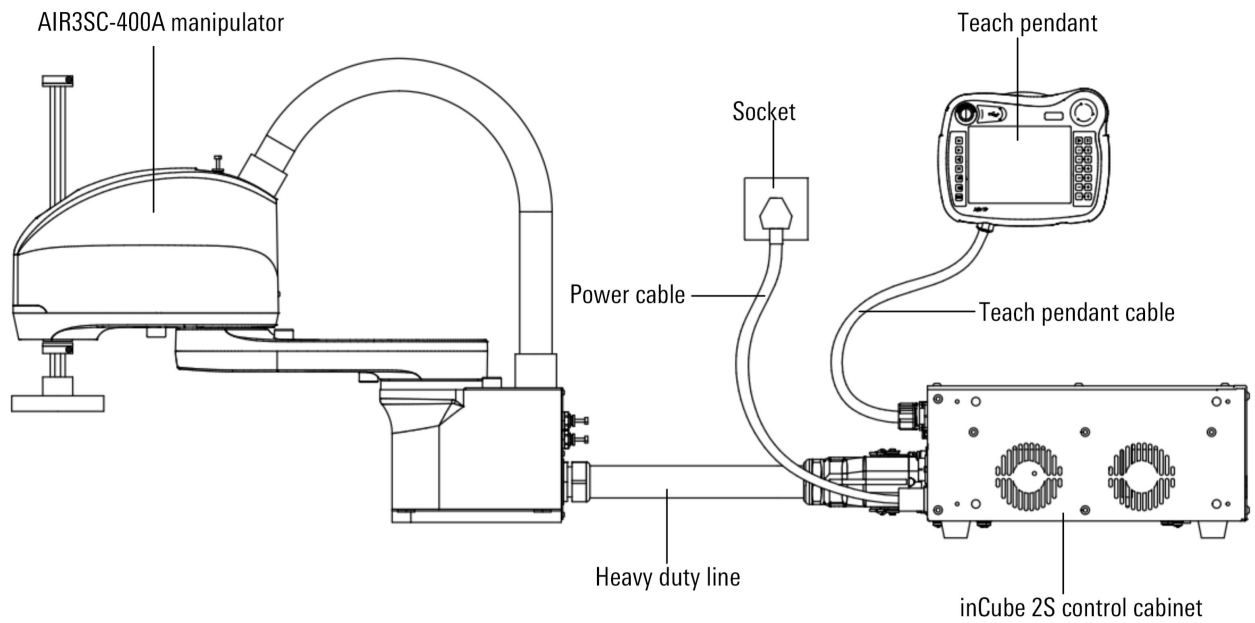

Figure 4-9 industrial robot system wiring overview

Both ends of the power cable are used to connect the control cabinet and the power supply (see Figure 4-9).

Connection steps:

- Step1. Confirm that the on-site power supply voltage and current meet the needs of the control cabinet (provide 220VAC voltage and meet at least 10A peak current load).
- Step2. Confirm that the safety short-circuit module of the control cabinet is connected normally (Figure 4-10 shows the normal connection status).

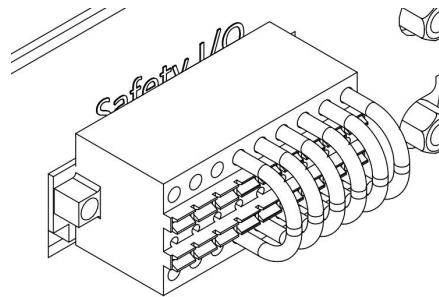

Figure 4-10 Safety short circuit module

- Step3. Connect the control cabinet. Insert the fret-shaped plug of the power cord into the power cord connection port of the control cabinet (see Figure 4-11).

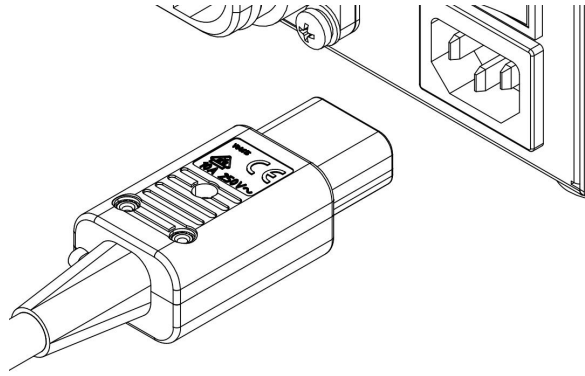

Figure 4- 11 Power cable connection interface

- Step4. Connect the power supply. Insert the three-head plug of the power cable into the power socket.
- Step5. After powering on, switch the switch from "0" to "I" (refer to Figure 4- 12), start the control cabinet, at the same time the switch indicator lights up, and the teach pendant starts.

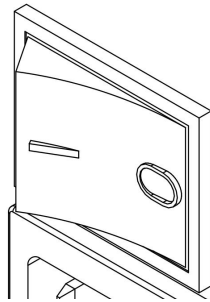

Figure 4- 12 Control cabinet power switch

- Step6. Before turning off the power, please confirm that the program has stopped running. Turn off the switch on the control cabinet after the motor is powered off. It is forbidden to unplug the power cable directly.

5. Job description

5.1. Safety precautions

Safety of peripheral equipment

Precautions related to the program:

- In order to detect a dangerous state, detection equipment such as limit switches should be used, and the manipulator should be stopped according to the signal of the detection equipment.
- When other manipulators or peripheral equipment are abnormal, even if the manipulator is not abnormal, corresponding measures should be taken, such as stopping the manipulator.
- If it is a system in which the manipulator and peripheral equipment operate synchronously, special attention should be paid to avoid mutual interference.
- In order to control the status of all equipment in the system from the manipulator, the manipulator and peripheral equipment can be interlocked, and the operation of the manipulator can be stopped as needed.

Precautions related to machinery

- The manipulator system should be kept clean and tidy and used in an environment that will not be affected by grease, water, dust, etc.
- Do not use cutting fluids and cleaning agents of unknown nature.
- Limit switches and mechanical limits should be used to limit the operation of the manipulator to avoid collisions between the manipulator and peripheral equipment.
- No user cables, hoses, etc. can be added to the manipulator.
- When installing cables, etc. outside the manipulator, please be careful not to obstruct the movement of the machine.
- For machine models where the inner cable of the manipulator is exposed to the outside, please do not make modifications that hinder the operation of the exposed part of the cable.
- When installing external equipment on the manipulator, take full care to avoid interference with other parts of the manipulator.
- For the manipulator in action, if the emergency stop button is used to frequently power off and stop the operation, it will cause the manipulator to malfunction.

Manipulator mechanical safety

Precautions during operation

When operating the manipulator through slow feed, no matter what the situation, the operator should maintain a high degree of vigilance and quickly respond to various problems.

Precautions related to the program:

When the action ranges of multiple manipulators overlap each other, full attention should be paid to avoid interference between the manipulators.

Be sure to set the specified operating origin for the manipulator program, and create a program that starts from the operating origin and ends at the operating origin, so that it can be clearly seen from the outside whether the manipulator has ended.

Precautions related to the institution

The working environment of the manipulator should be kept clean, so that the manipulator is used in an environment that is not affected by grease, water, dust, etc.

Safety of end effector

When controlling various transmission devices (pneumatic, hydraulic, electrical), after issuing a control command, the time difference between the command and the actual action should be fully considered, and control with a certain amount of flexibility should be carried out.

The detection unit should be installed on the end effector to monitor the state of the end effector and control the action of the manipulator.

5.2. Safe operation

5.2.1. LED indicator

Please refer to Figure 2- 2 for the location of the LED indicator. The meaning of each color is shown in Table 5- 1

Table 5- 1 The meaning of each color of the LED indicator

Display	Working status
Red light is always on	Alarm\emergency stop button trigger state
Yellow light is always on	Calibration\Manually release the brake button is triggered\Starting
Green light is always on	All normal states after power-on (including upper enable, lower enable and running status, etc.)
Light does not shine	Shutdown



When the LED light is turned on, power is supplied to the robot. It is extremely dangerous to work with the power on and may cause electric shock or malfunction of the robot system. Be sure to turn off the power to the controller before performing maintenance work.

5.2.2. Structural dimensions

The dimensions of each component assembly of the manipulator are shown in Figure 5- 1.

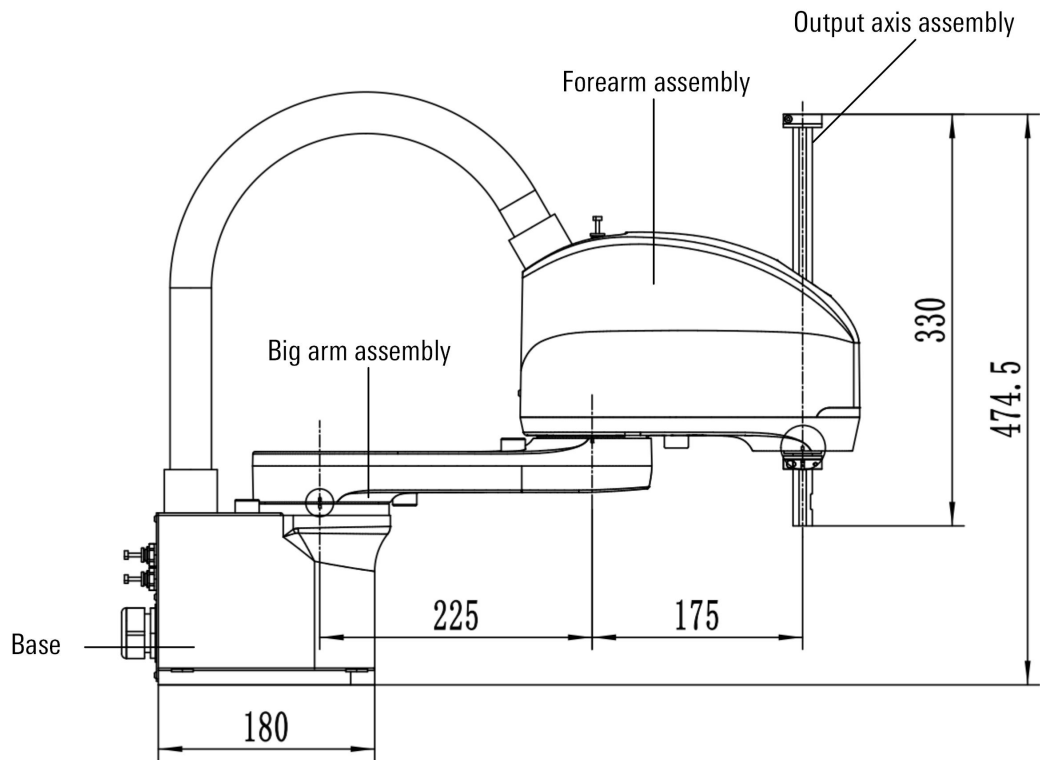

Figure 5- 1 Assembly size of manipulator components

5.2.3. Working range of each axis

The movement range of each axis of manipulator is shown in Table 5- 2.

Table 5- 2 Movement range of each axis of manipulator

Axis number	Range of motion
J1	-136° ~ +136°
J2	-141° ~ +141°
J3	-150 ~ 0mm
J4	-360° ~ +360°

The operation range of the manipulator is shown in Figure 5- 2.

When installing peripheral equipment, take care to avoid interference with the main part of the robot and the range of motion. Unit: mm.

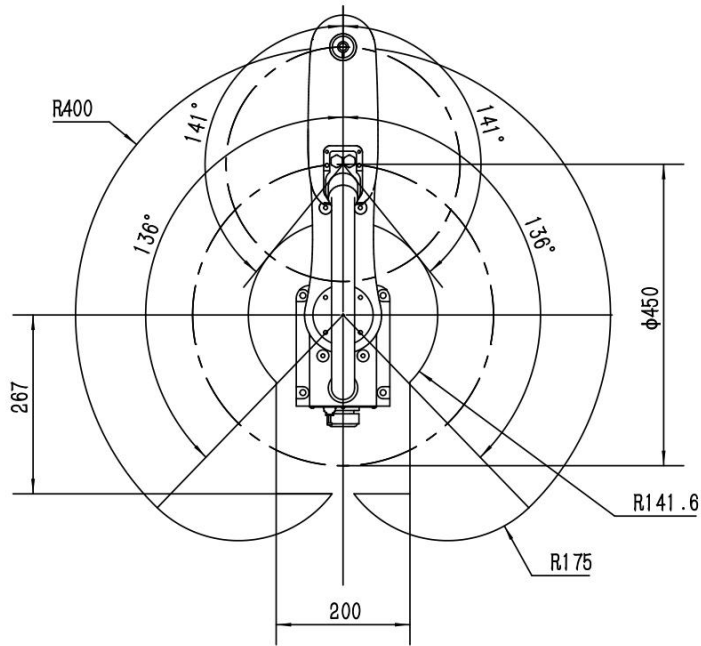

(a) Top view

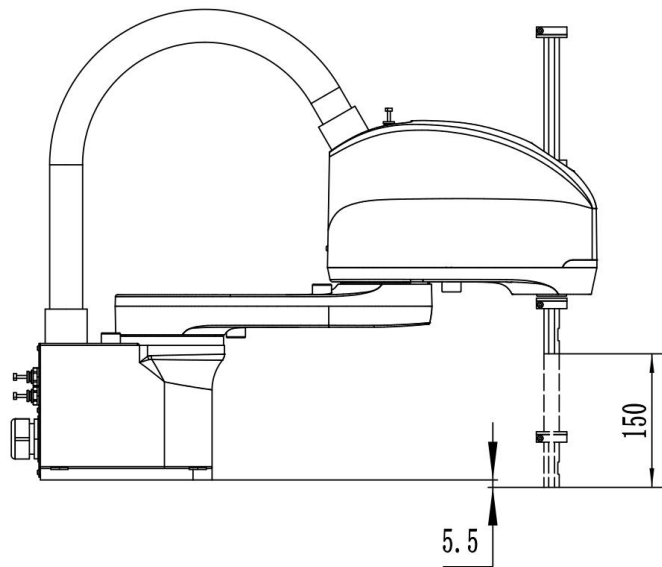

(b) Front view

Figure 5-2 Operating range of manipulator

5.2.4. Mechanical limit

Each axis of the manipulator is equipped with a zero point and a movable range. As long as the origin position is not lost due to servo system abnormalities and system errors, the robot is controlled to move within its movable range. In addition, in order to further ensure safety, except for the 4-axis mechanical body without a limit device, the 1/2/3 axis has a mechanical limit, as shown in Figure 5-3.

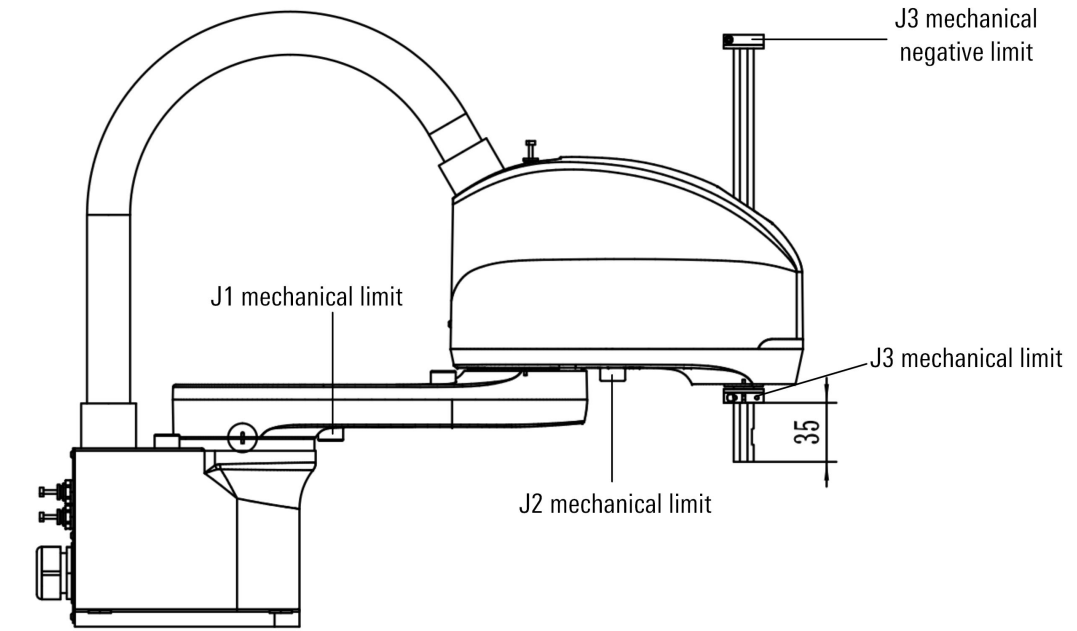

(a) J3 positive and negative limit

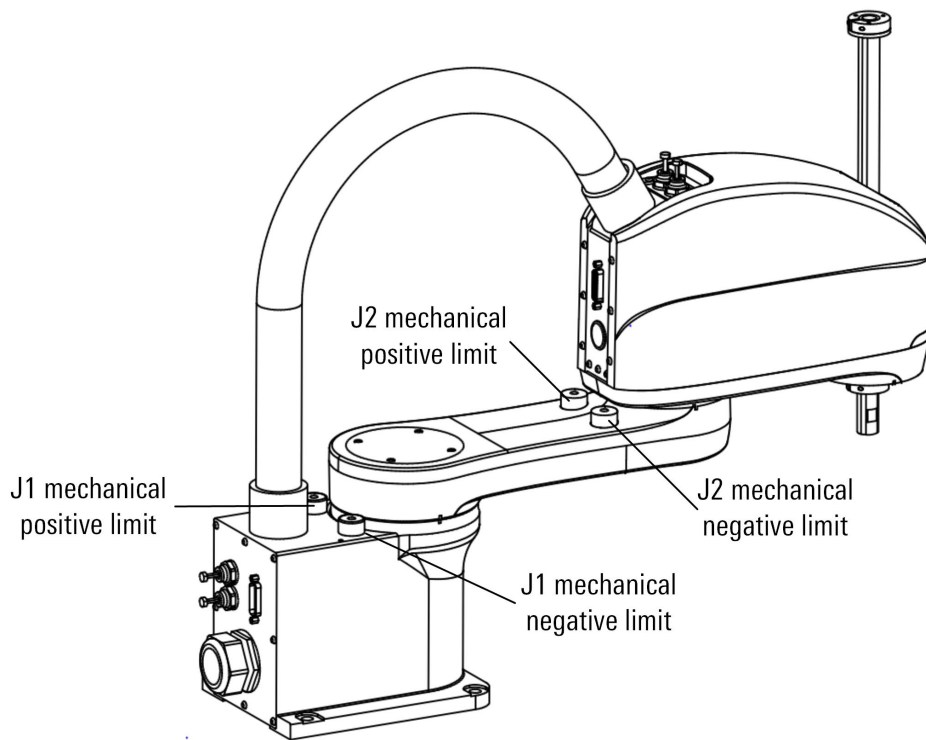

(b) Positive and negative limits of J1 and J2 axis

Figure 5- 3 Mechanical limit of manipulator

 Caution	Do not modify the mechanical limit, otherwise the robot may not stop normally.
	The distance between the lower end of the J3 mechanical positive limit and the bottom of the screw is 35mm, and the upper end of the J3 negative limit is flush with the top of the screw.
	Both the positive and negative limits of J3 are fixed with M3 screws. When tightening, please refer to the 8.8 torque standard of DIN267.

5.2.5. Stop mode

According to the definition of stop function in 9.2.2 of GB5226.1-2008 "Mechanical and Electrical Safety-Part 1: General Technical Conditions", combined with the specific design of the robot, the definition of 3 stop modes and corresponding descriptions are shown in Table 5- 3:

Table 5- 3 Stop method and corresponding instructions

Type	Description	
STOP0	Case1	CCB alarm stop0 indicate, DCB will stop immediately without keeping track, and then CCB delay control will cut off the power through the SCR enable, which is an uncontrollable stop
	Case2	DCB has an uncontrollable fault, triggering a free stop or brake stop, which is an uncontrollable stop
	Case3	Sudden external power failure, DCB cannot perform immediate stop, trigger brake to stop, which is an uncontrollable stop
STOP1	Make the robot stop quickly and maintain the current planned path. When the robot stops, control the drive serve_off and cut off the power supply through the thyristor, which is a controlled stop	
STOP2	Make the robot stop quickly and need to maintain the current planned path. When the robot stops, do not serve_off and do not cut off the power supply, which is a controlled stop	

5.3. Calibration

5.3.1. When is calibration required

When the following situations occur in the manipulator, recalibration is required:

- There has been maintenance such as motor replacement or pulley removal.
- The encoder battery has been replaced.
- The encoder cable of the motor is loose or reinstalled
- The manipulator has experienced a strong collision.
- The control cabinet or control system (such as industrial computer) is replaced.

5.3.2. Calibration position of each axis

 Prompt	Please refer to " Horizontal Multi-joint Industrial Robot System Quick Start Manual" for detailed operation method during calibration.
---	--

The calibration position of each axis of the manipulator is shown in Figure 5- 4. When the bottom surface of the screw spline is 50mm from the lower end of the forearm, the calibration position is 0; the other axes are all 0°.



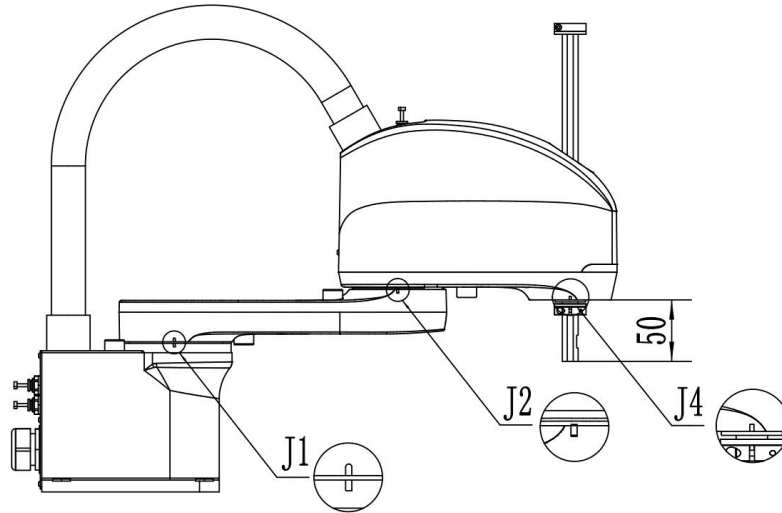

Figure 5- 4 Schematic diagram of the zero point of each axis of

As shown in Figure 5- 4, for the 1-axis and 2-axis, you need to align the calibration grooves as shown to complete the calibration; the 3-axis calibration tool is shown in Figure 5- 5, and the method of use is shown in Figure 5- 6. One end is attached to the lower end of the forearm, and the screw is moved. When the lower end of the screw and the lower end of the calibration tool are in the same horizontal plane, the 3-axis calibration is completed.

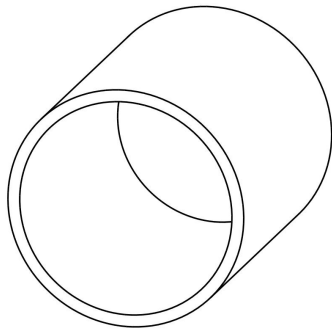

Figure 5- 5 J3 calibration tooling

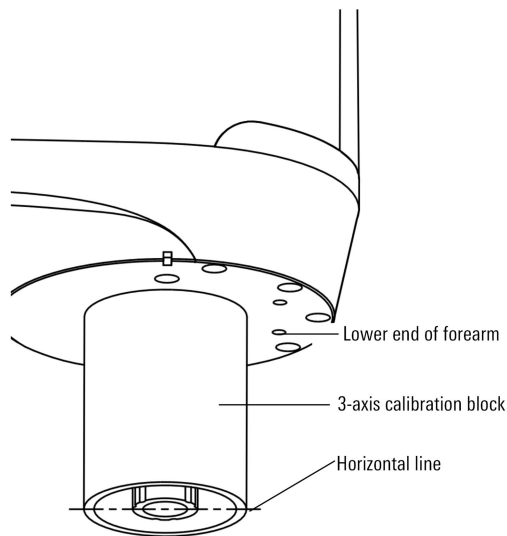

Figure 5- 6 J3 calibration diagram

The 4-axis calibration method is shown in Figure 5-7. Align the 4-axis calibration slot on the forearm with the slot on the lower limit block of the 4-axis to complete the calibration. In order to ensure the accuracy of calibration, avoid changing the position of the limit block.

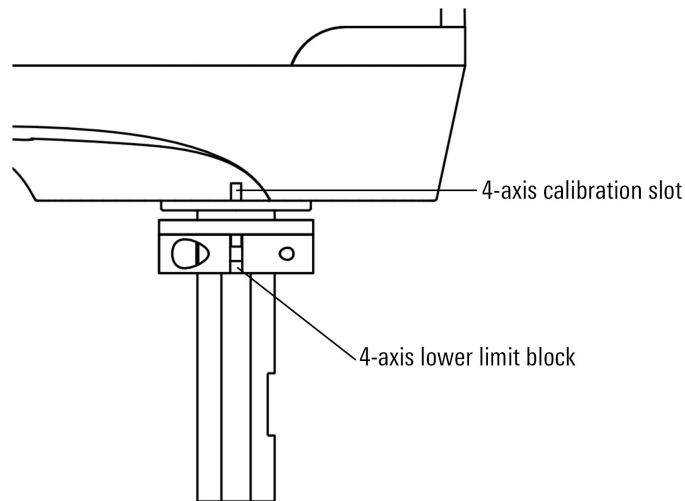

Figure 5- 7 J4 calibration diagram



Caution

The robot calibration must always be performed under the same temperature conditions to avoid errors caused by thermal expansion and contraction.

The industrial robot must be calibrated sequentially from the J1 axis to the J4 axis.

5.3.3. Movement direction of each axis

The positive and negative directions of the rotation or linear movement of the 1 to 4 axes of the manipulator (refer to Figure 5- 8) are defined as follows:

- Looking down on the manipulator, the counterclockwise direction of axis 1, 2, and 4 is positive, and the clockwise direction is negative;
- 3 axis upward movement is positive, downward movement is negative

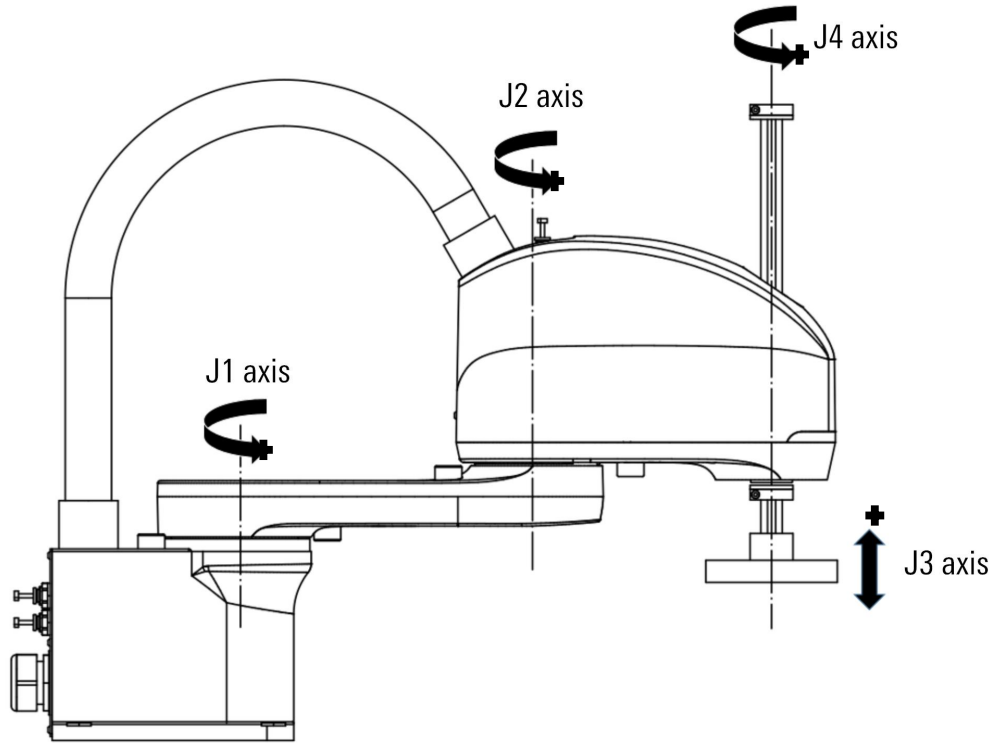

Figure 5- 8 Schematic diagram of the movement direction of each axis of the manipulator

5.3.4. Speed of each axis

The maximum angular velocity of each axis of the manipulator is shown in Table 5- 4.

Table 5- 4 Maximum angular velocity of each axis of manipulator

Axis number	Allowable maximum angular velocity
J1	600° /s
J2	600° /s
J3	1100 mm/s
J4	2600° /s

5.4. Flange size

The connection dimensions and connection dimensions of the output shaft are shown in Figure 5- 9.

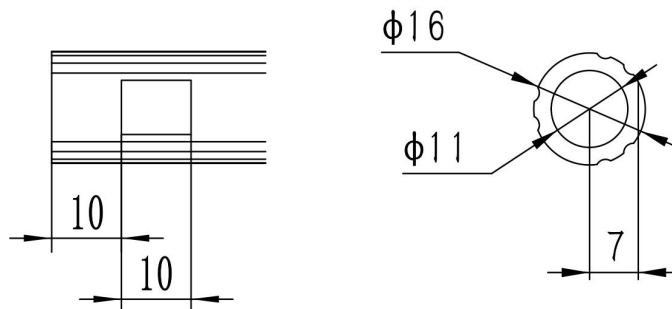

Figure 5- 9 Schematic diagram of wrist flange size of manipulator



When installing the fixture, it is recommended to use M4 screws to ensure the clamping strength.

5.5. Load installation

Installation requirements



When the mass, moment of inertia and offset of the center of gravity of the installed load exceed the rated values, please consult the manufacturer for the best parameter settings.

If the load is installed and operated, it may come into contact with the manipulator due to the outer diameter of the load, the size of the workpiece, or the position of the manipulator shaft. When arranging the system, please pay full attention to the interference area of the load.

- The load installed at the end of the screw spline has a rated mass of 1kg, and the maximum load mass shall not exceed 3kg.
- The moment of inertia of the installation load relative to the axis of the screw rod, the rated inertia is 0.005 kg·m², and shall not be greater than 0.05 kg·m².
- When a camera, pneumatic valve, etc. are installed on the robotic arm, the weight needs to be converted to the equivalent weight of the shaft and added to the load weight.

When installed on both sides of the forearm (shown in Figure 5- 10) $WM = M (L1)^2 / (L1 + L2)^2$

When installed at the top of the forearm (shown in Figure 5- 10): $WM = M (LM)^2 / (L2)^2$

WM:Equivalent weight

M:Weight of camera, etc.

L1:Length of big arm

L2:Length of forearm

LM:The distance from the center of rotation of the J2 axis (shown in Figure 5- 10) to the center of gravity of the camera, etc.

- The rated center offset is 0mm, and the maximum center offset is 100mm.

Camera installation

The manipulator has a camera mounting position on the forearm, and the mounting hole specifications and dimensions are shown in Figure 5- 10.

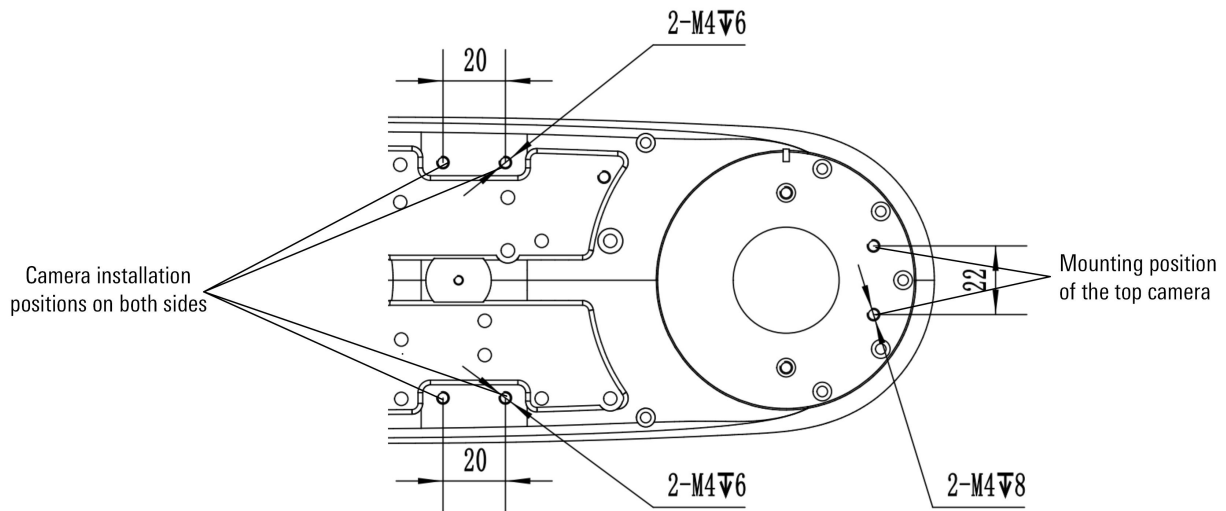

Figure 5- 10 Schematic diagram of the camera installation position of the arm



Warning

When installing the equipment, the screw used should be fully considered the depth of the threaded hole, and the installation length is prohibited to exceed the depth of the threaded hole, otherwise the installation accuracy will be affected.

The above parts are designed for camera fixation. Pay attention to converting the related camera quality into load quality and ensure that the total load is within the required range.

When installing the equipment, it is necessary to fully consider the reliability of the installation. It is recommended to use grade 12.9 screws to install according to the specified torque, and apply thread glue to the threads. Otherwise, the long-term operation may loosen or even break, causing accidents.

6. Transportation and handling

6.1. Transport attitude

The posture diagram of the manipulator is shown in Figure 6- 1 during transportation. Try to make the J1 mechanical negative limit on the base contact with the J1 mechanical limit on the big arm assembly. The J2 mechanical positive limit on the big arm assembly is in contact with the J2 mechanical limit on the forearm assembly.

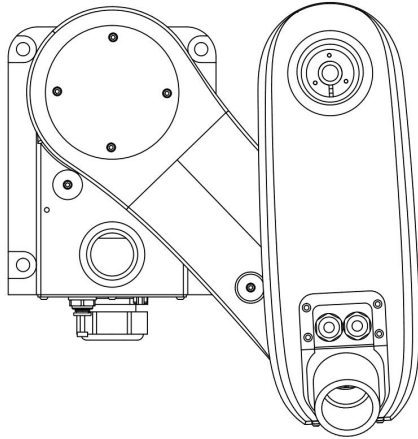

(a) Top view of handling posture

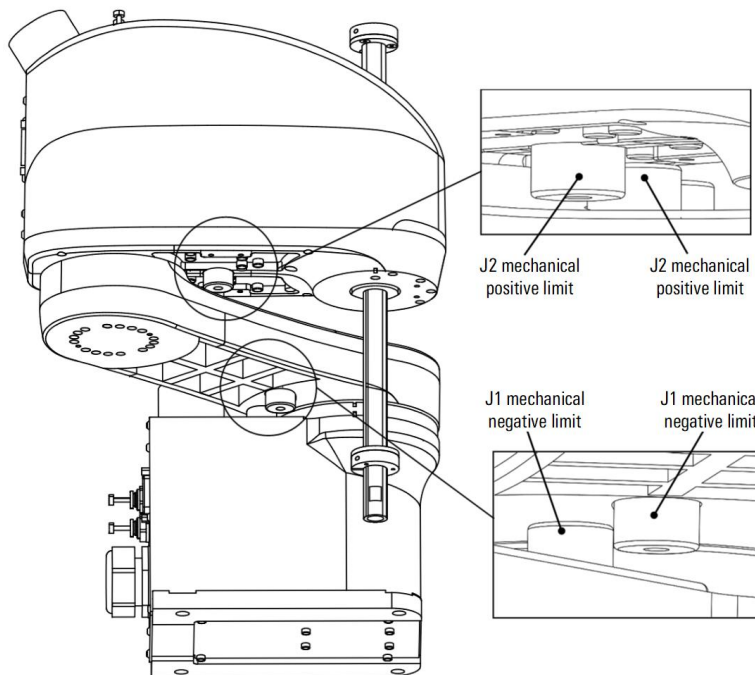

(b) Schematic diagram of limit block contact

Figure 6- 1 Pose diagram of manipulator handling



The manipulator must strictly follow the posture shown in Figure 6- 1 when being transported, otherwise it may tip over due to an unstable center of gravity.

6.2. Transport dimensions

Refer to Figure 6- 2 for the dimensions of the three views of the manipulator during transportation.



The actual size may be slightly larger than the size in Figure 6- 2, so be careful.

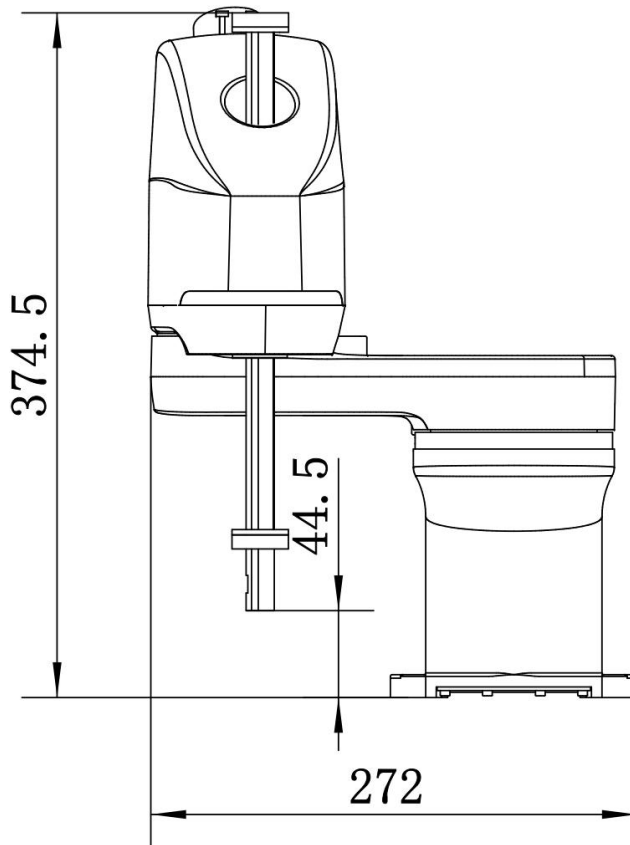

(a) Main view

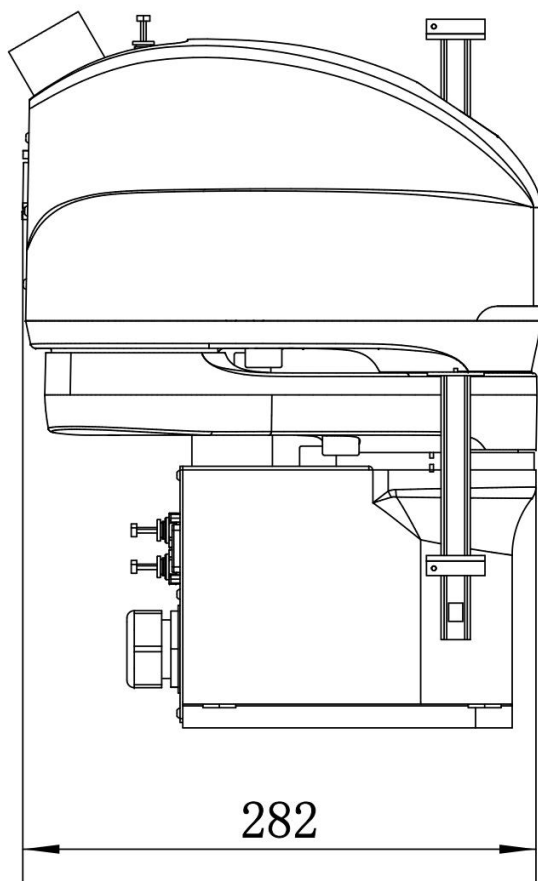

(b) Left view

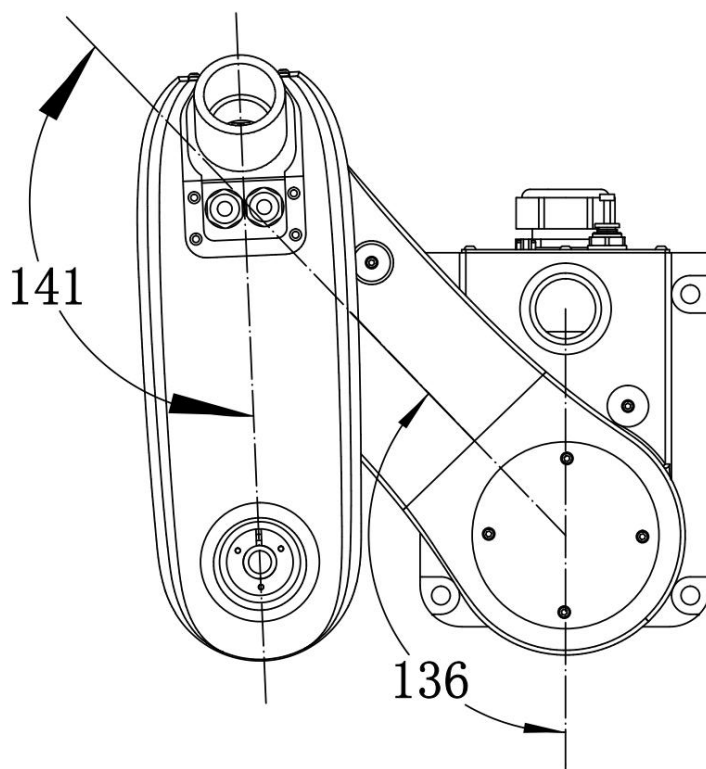

(c) Top view

Figure 6-2 size of the manipulator during transportation

6.3. Handling method

Please try to transport the robot with a trolley, etc. in the same way as it was delivered.

Precautions:

- When carrying the robot, please fix the robot on a carrying tool (such as a cart), or hold the shaded part (under the first arm and under the base, refer to Figure 6- 3) with your hands and carry it by more than 2 people;

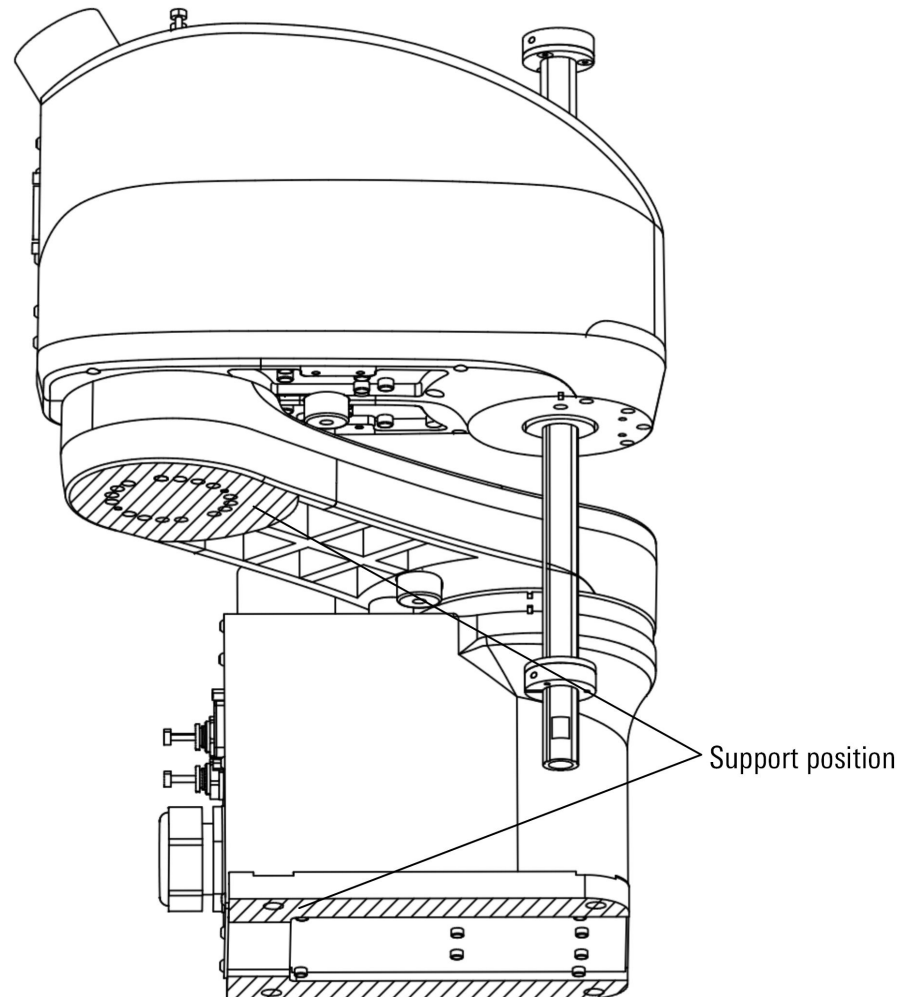

Figure 6- 3 Schematic diagram of the supporting position of the handling manipulator

- When holding the bottom of the base, please be careful not to pinch your fingers;
- When transporting over long distances, please fix the robot directly on the transport equipment to prevent it from tipping over;
- Please carry out the same packaging as the delivery time according to your needs.

7. Preventive maintenance

7.1. Safety protection measures

Precautions during maintenance



Warning

When the power is turned on, there is a danger of electric shock in part of the maintenance operations. The maintenance operations should be performed with the manipulator and system power off as much as possible; professional maintenance personnel should be designated as needed to perform maintenance operations; other personnel should be avoided during maintenance operations. Turn on the power; even in the case where the power must be turned on before the work can be performed, press the emergency stop button before proceeding.

When you need to replace parts, please consult our company.

The customer's independent replacement of parts may cause unexpected accidents, damage the manipulator, and cause injury to the operators.

If you need to replace parts, be sure to use the parts designated by our company. If parts other than the specified parts are used, it may cause damage to the manipulator.

When disassembling the motor and brake, take measures such as lifting by a crane before dismantling, so as to prevent the manipulator arm from falling.

During maintenance operations, when the manipulator needs to be moved due to unavoidable circumstances, the following items should be noted:

- Make sure that the escape route is unblocked, and you should perform operations after you have grasped the operation of the entire system to avoid blocking the exit route by the manipulator and peripheral equipment.
- Always pay attention to whether there are dangers around and be prepared so that you can press the emergency stop button at any time when needed.

When moving parts with a certain weight such as motors and reducers, auxiliary equipment such as cranes should be used to avoid excessive work burdens on operators. At the same time, it is necessary to avoid wrong operation, otherwise it may cause injury or death of the operator.

Be careful not to fall down because of the lubricating oil spilled on the ground. Wipe off the lubricating oil on the ground as soon as possible to eliminate possible dangers.

During the operation, do not put any part of the body on any part of the manipulator, and it is forbidden to climb on the manipulator to avoid unnecessary personal injury or adverse effects on the manipulator.

The following parts will generate heat, so be careful. When it is necessary to touch the device under heat, you should prepare protective equipment such as heat-resistant gloves:

- Servo motor
- Reducer
- Components adjacent to the motor/reducer
- Inside the control cabinet

The parts (such as screws, etc.) that are removed when replacing parts should be correctly installed back to their original positions. If parts are found to be insufficient or there are remaining parts, they should be reconfirmed and installed correctly.

When repSOTing the pneumatic system and hydraulic system, be sure to release the internal pressure to 0 before proceeding.

When replacing parts, avoid dust and other foreign objects from entering the inside of the manipulator.

Operators who perform maintenance and repSOT operations must be trained by our company and pass relevant assessments.

Appropriate lighting equipment should be equipped for maintenance work, but care should be taken

not to make the lighting equipment the source of new hazards.

Please refer to this manual for regular maintenance. Failure to perform regular maintenance will affect the service life of the manipulator and may result in accidents.

Safety of maintenance engineers

In order to ensure the safety of maintenance engineers, the following items should be fully paid attention to:

- During the operation of the manipulator, do not enter the operating range of the manipulator.
- Carry out maintenance work with the power supply of the control device disconnected as much as possible. The main circuit breaker should be locked with a lock, etc. as needed to prevent other people from turning on the power.
- When it is necessary to enter the working range of the manipulator during power-on, you should press the emergency stop button of the control cabinet or the teach pendant before entering. In addition, the operator should put up a "maintenance operation" sign to remind other personnel not to operate the manipulator at will.
- Before performing maintenance work, confirm that the manipulator or peripheral equipment is in a safe state.
- Do not perform automatic operation when there are people in the operating range of the manipulator.
- When working near walls, appliances, etc., or when several operators are close, be careful not to block the escape passages of other operators.
- When there are knives on the manipulator, and when there are moving devices such as conveyor belts in addition to the manipulator, pay full attention to the actions of these devices.
- A person who is familiar with the manipulator system and can detect the danger should be arranged beside the operation panel and operation box during operation, so that they can press the emergency stop button at any time.
- When replacing parts or reassembling, pay attention to avoid foreign matter adhesion or mixing.
- When inspecting and repSOTing the inside of the control device, if you want to touch the unit, printed circuit board, etc., in order to prevent electric shock, be sure to disconnect the power supply of the main circuit breaker of the control device before proceeding.
- The replacement parts must use the parts designated by our company.
- When restarting the manipulator system after the maintenance work is completed, fully confirm in advance that no one is within the operating range of the manipulator, and that the manipulator and peripheral equipment are in normal state.

7.2. Daily maintenance

When operating the manipulator every day, check the items shown in Table 7- 1.

Table 7- 1 Daily maintenance items of the manipulator

No.	Check item	Check essentials
1	Vibration, sound, motor heating	Whether there is abnormal vibration or noise on each axis, and whether the motor temperature is abnormally high.
2	Whether the positioning accuracy changes	Check whether it deviates from the last start position and whether there is a deviation in the stop position
3	Operation confirmation of peripheral equipment	Confirm that the actions of the manipulator and peripheral equipment are consistent with the instructions

7.3. First maintenance

The operation machine shall run for the first time 320 hours or 1 month (whichever is shorter), and the following items shall be inspected and maintained. As shown in Table 7- 2:

Table 7- 2 Manipulator First Maintenance Project.

No.	Inspection item	Main points of inspection
1	Whether the cable and cable sheath of the operator are damaged differently and whether the motor connector is loose	Observe the cable activity part of the manipulator, check whether the cable is damaged, whether the cable is bent or distorted locally, check whether the cable sheath is damaged or not, and check whether the motor connector is loose (Note 1)
2	End effector mounting screws	Check whether the bolts are loose and tighten them with a torque wrench (Note 2)
3	Lock bolts of each arm	Check whether the bolts are loose and tighten them with a torque wrench (Note 2)
4	Bolts for motors, reducers, etc.	Check whether the bolts are loose and tighten them with a torque wrench (Note 2)
5	Clean all parts of the manipulator	Clean and maintain the parts of the manipulator, and check whether the parts are damaged (Note 3).
6	Whether the terminal actuator cable is damaged or not	Inspect the cable for damage, and the cable sheath is damaged
7	Whether the timing belt is worn	Check the timing belt for wear, elongation, and breakage (Note 4)
8	Whether the timing belt is slack	Check the tension of the timing belt and adjust it. Specific consulting manufacturers
9	Grease state	Check the lubrication status
10	battery	Replace every 2 years
11	Check whether the limit blocks are damaged or loose	Check whether the limit block is loose, collision damage, etc.

Note 1:**Check and RepSOT Points**

- Whether the bellows is severely worn.
- Whether the bellows connection and the heavy-duty line connection are loose.
- Whether the cable is severely bent and damaged.

Confirmation

- Whether the bellows has abnormal noise or cracks.
- The bellows joints and heavy-duty joints are loose and can be turned by hand.
- Check whether the wiring is worn out, and replace the internal wires if they can be seen.
- Circular connector: turn it by hand to see if it is loose.
- Grounding terminal: confirm whether it is loose.

Note 2:**Fastening part**

- Tighten the end effector mounting bolts, manipulator fixing bolts, etc.

- The external connection screws of the manipulator, especially the connection screws of each shaft and the reducer.
- For tightening torque, please refer to the recommended values in the appendix of this manual.

Note 3:**About timing belt maintenance**

- After disassembling the outer shell of the forearm, observe whether the timing belt is worn or damaged. For removing the cover, please refer to *Chapter 8.4* in this manual.
- Observe whether there is white hSOT inside the teeth of the timing belt, whether the belt side is worn, whether the belt teeth are crushed, whether the belt body is broken, whether the belt body is stretched (decreased preload), etc.

7.4. Regular maintenance

Regular maintenance for 960 h (3 months)

The following check and repSOT items shall be done for manipulator after the 960 h or 3 months (whichever comes first). As shown in Table 7-3.

Table 7-3 Maintenance Items for 960 h (3 months)

No.	Check Item	Essentials
1	Cleaning of control cabinet vent	Remove the dust accumulated at control cabinet vent
2	Cleaning of manipulator	Wipe off the dirt and remove the accumulated splash, dust, chip, etc.

Regular maintenance for 1,920 h (6 months)

The following check and repSOT items shall be done for manipulator after the 1,920 h or 6 months (whichever comes first). As shown in Table 7-4.

Table 7-4 Maintenance Items for 1,920 h (6 months)

No.	Check Item	Essentials
1	Check whether the manipulator cable and cable sheath are damaged	See the first maintenance in <i>Chapter 7.3</i> .
2	Whether the timing belt is worn out.	Check the synchronous belt for wear, elongation and breakage

Regular maintenance for 3,840 h (1 year)

The following check and repSOT items shall be done for manipulator after the 3,840 h or 1 year (whichever comes first). As shown in Table 7-5:

Table 7-5 Maintenance Items for 3,840 h (1 year)

No.	Check Item	Essentials
1	Check whether the manipulator cable and cable sheath are damaged	See the first maintenance in <i>Chapter 7.3</i> .
2	Fasten the main external bolts	See the first maintenance in <i>Chapter 7.3</i> .

No.	Check Item	Essentials
3	Clean the parts of manipulator	See the first maintenance in <i>Chapter 7.3</i>
4	Check whether the cables of end effector are damaged	See the first maintenance in <i>Chapter 7.3</i>
5	Replacement of Synchronous Belt	See the first maintenance in <i>Chapter 7.3</i>
6	Check whether the limit rubber block of J1 axle is damaged	See the first maintenance in <i>Chapter 7.3</i>

Regular maintenance for 7,860 h (2 years)

The following check and repSOT items shall be done for manipulator after the 7,860 h or 2 years (whichever comes first). As shown in Table 7- 6:

Table 7- 6 Maintenance Items for 7,860 h (2 years)

No.	Check Item	Essentials
1	Battery Replacement	See <i>the first maintenance in Chapter 8.3.</i>

Regular maintenance for 11,520 h (3 years)

The following check and repSOT items shall be done for manipulator after the 11,520 h or 3 years (whichever comes first). As shown in Table 7- 7:

Table 7- 7 Maintenance Items for 11,520 h (3 years)

No.	Check Item	Essentials
1	Replacement of Synchronous Belt	See <i>the first maintenance in Chapter7.3.</i>

Regular maintenance for 15,360 h (4 years)

The following check and repSOT items shall be done for manipulator after the 15,360 h or 4 years (whichever comes first). As shown in Table 7- 8:

Table 7- 8 Maintenance Items for 15,360 h (4 years)

No.	Check Item	Essentials
1	Replace the internal cables of manipulator	Replace the manipulator cable, please consult with us

Regular maintenance for 19,200 h (5 year)

The manipulator shall be overhauled with many parts replaced for 5 years or 192,000 h (whichever comes first). Please contact us. As shown in Table 7- 9:

Table 7- 9 Maintenance Items for 19,200 h (5 years)

No.	Check Item	Essentials
1	Manipulator overhaul	Please consult with us

7.5. Grease filling

Ball screw splines and reducers need to be greased regularly. Be sure to use the specified grease, refer to Table 7- 10.

Table 7- 10 Manipulator grease filling maintenance project

Lubrication components	Lubrication parts	Lubrication interval	Grease	Grease filling method
First joint	Reducer	10,000 hours or 2 years, whichever comes first	Please consult the manufacturer for details	Please consult the manufacturer for details
Second joint	Reducer	10,000 hours or 2 years, whichever comes first	Please consult the manufacturer for details	Please consult the manufacturer for details
Screw spline	Screw spline	6 months or 100 km, whichever comes first	Please consult the manufacturer for details	Please consult the manufacturer for details



Caution

Please pay attention to avoid running out of grease. If the grease is used up, the sliding parts will have scratches, etc., which will not only fail to achieve full performance, but also will take a lot of time and cost to repSOT.

Once the grease enters the eyes, mouth, or adheres to the skin, perform the following treatments:

- When entering the eyes: wash your eyes thoroughly with clean water, and then seek medical attention;
- When entering the mouth: Do not force vomiting when swallowing, and seek medical attention immediately;
- When entering your mouth: rinse your mouth thoroughly with water;
- When it adheres to the skin: rinse with water and soap.

8. Project maintenance process

8.1. Cleaning the manipulator

In order to ensure the long-term operation of the robot, the manipulator should be cleaned regularly every 960 hours or 3 months of operation (whichever is shorter).

Cleaning steps:

Step1. Adjust the robot to the zero position of each axis, refer to **Chapter 5.3**.

Step2. To prevent danger, turn off the power, hydraulic and SOT pressure sources connected to the robot.

Step3. Use a vacuum cleaner to clean the manipulator, or wipe with a cloth.

Step4. After ensuring that all safety conditions (refer to **Chapter 5.1**) are met, proceed with the follow-up work of the manipulator.



It is forbidden to use water jet on the manipulator, especially the joints and seals.

It is forbidden to use compressed SOT to clean the manipulator.

It is forbidden to remove any manipulator protection device

Do not use solvents to clean the manipulator

8.2. Check and repSOT cables

To ensure that the robot can run for a long time, every 1920 hours or 6 months of operation (whichever is shorter), the manipulator cable should be checked.

Check and repSOT the internal cables of the base

Maintenance steps:

Step1. Use an Allen key to loosen the M3×6 hexagon socket flat head screws on the rear cover of the base, and remove the rear cover and the connector on it, as shown in Figure 8- 1.

Step2. Check whether the internal cables are worn or damaged.

Step3. Check whether the connector is loose or damaged.

Step4. If there is crack, abrasion or damage, please contact our company for replacement in time.

Step5. After confirming that there is no problem, install the cable into the base as it is.

Step6. Install the rear cover, put it back as it is, and check the ventilation of the trachea.

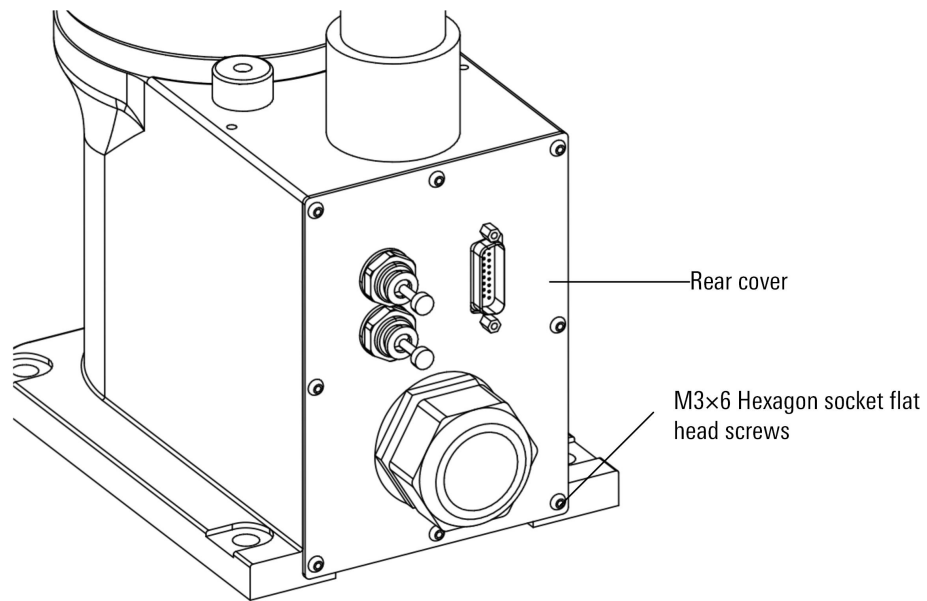
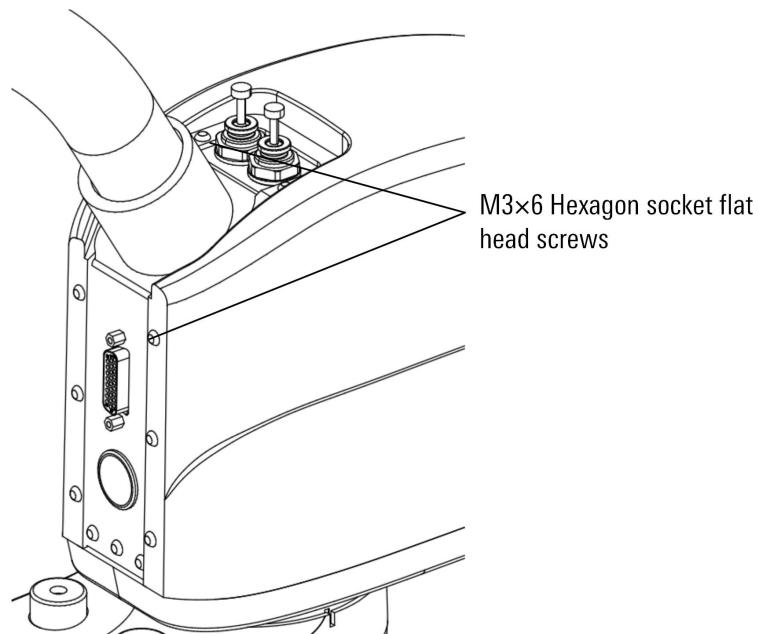

Figure 8- 1 Cable maintenance inside the base

Check and repSOT the internal cables of the forearm body

Maintenance steps:

- Step1. Use an Allen wrench to remove the 10 M3x6 hexagon socket flat head screws and four M3x30 hexagon socket head screws that fix the forearm shell, and remove the forearm shell, refer to Figure 8- 3.



(a) Remove the top and rear screws

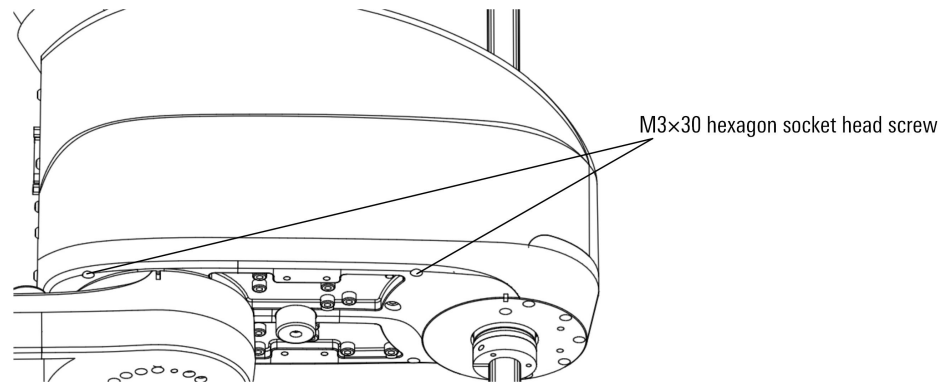

(b) Remove bottom screw

Figure 8- 2 Schematic diagram of removing the screws of the forearm shell

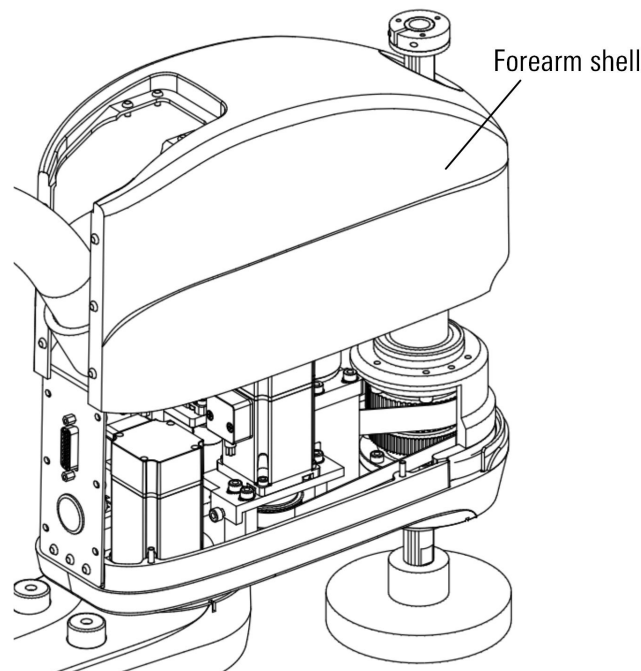

Figure 8- 3 Maintenance of internal cables of forearm and body

- Step2. Check whether the cable and sheet metal connection are reliable.
- Step3. Check whether there is abrasion or damage at the cable and sheet metal fixing place.
- Step4. If there is crack, abrasion or damage, please contact our company for replacement in time.
- Step5. Install the forearm shell.

8.3. Replacing the battery

The position data of each axis of the manipulator is saved by the encoder battery. Every 7860 hours or 2 years of operation (whichever is shorter), or the driver prompts A2 alarm, the battery should be replaced in time.

Replacement steps:

- Step1. Adjust the robot to the calibration state.
- Step2. To prevent danger, turn off the power, hydraulic and SOT pressure sources connected to the robot.

- Step3. As shown in Figure 8- 4, remove the fixing screws of the base and place it horizontally. Pay attention to the foam or soft pad underneath to prevent the main body from being hit.

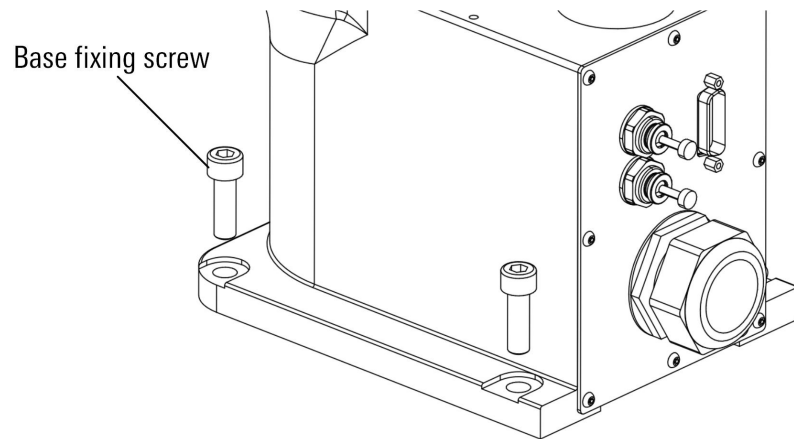

Figure 8- 4 Schematic diagram of removing the base fixing screws

- Step4. Use an Allen wrench to remove the eight M3×8 hexagon socket head screws located on the bottom cover and remove the bottom cover of the manipulator base. Pay attention to the internal cables to prevent damage caused by strong pulling. Disconnect the connector and remove the battery box fixing sheet metal from the bottom cover, you can see the battery, as shown in Figure 8- 5.

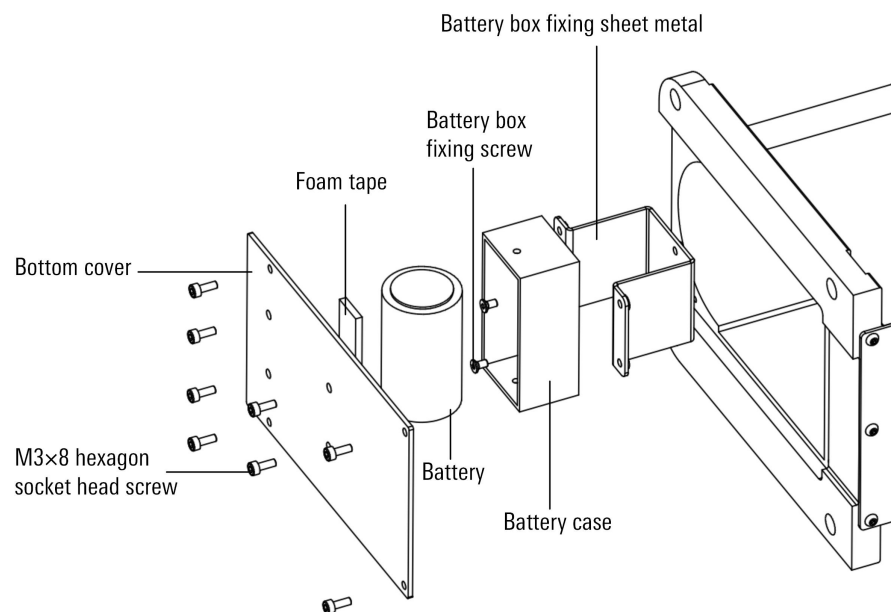



Figure 8- 5 Schematic diagram of removing the battery box

- Step5. Remove the old battery from the battery box, and put the new battery into the battery box. Note that the positive and negative polarity of the battery is consistent with the old battery.
- Step6. Put the battery box fixing sheet metal back on the bottom cover and insert the connector.
- Step7. After ensuring that all safety conditions (refer to **Chapter 5.1**) are met, perform the calibration and testing of the manipulator.

 Prompt	Replacing the encoder cable battery, etc. will cause the encoder position analysis value to be lost, and the zero position will deviate. At this time, it is necessary to perform "zero point calibration" again. For the specific calibration method, please refer to the "Horizontal Articulated Industrial Robot System Quick Start Manual" of our company.
---	--

8.4. Replace timing belt

Every time the manipulator runs for 3840 hours or 1 year (whichever is shorter), it is necessary to replace the J3 and J4 axis timing belts. For synchronous belt models, see Table 8- 1.

Table 8- 1 Manipulator timing belt model

Synchronous belt model	Position of timing belt
	J3 axis inside forearm
	J4 axis primary transmission inside the forearm
	J4 axis two-stage transmission inside the forearm

Replace J3 axis timing belt

The replacement process is as follows:

- Step1. Cut off the power supply of the control device.
- Step2. Use an Allen wrench to remove the M3×6 hexagon socket head screws and M3×30 hexagon socket head screws that fix the forearm shell, and remove the forearm shell, refer to Figure 8- 6.

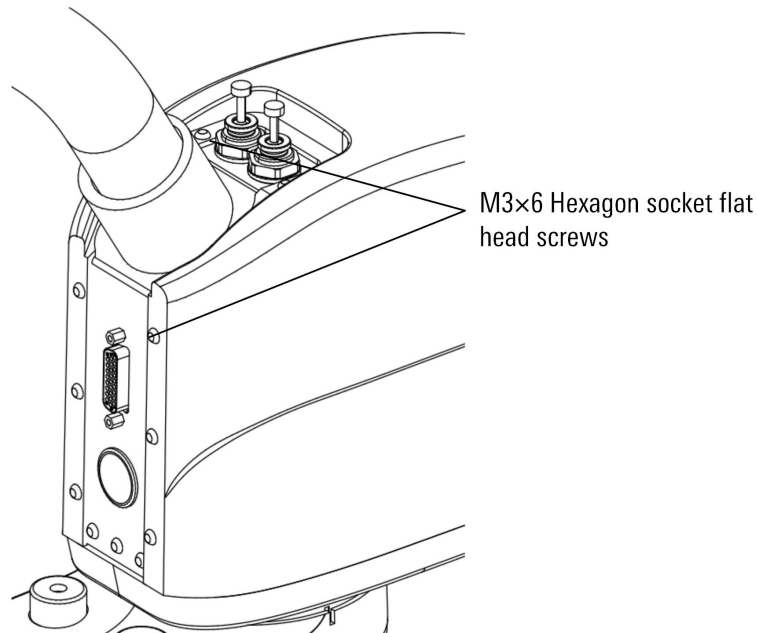

(a) Remove the top and rear screws

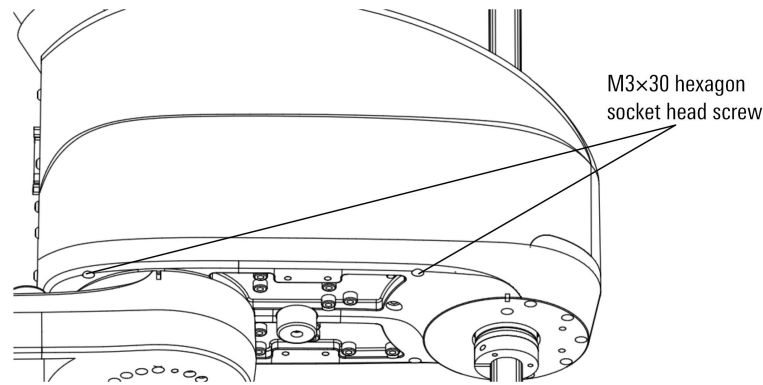

(b) Remove bottom screw

Figure 8- 6 Schematic diagram of removing the screws of the forearm shell

- Step3. Use an Allen wrench to remove the four M4×10 inner hexagon socket head screws that fix the flange of the 3-axis motor, and then slowly loosen the a M4×10 inner hexagon socket head screw that adjusts the tension of the 3-axis synchronous belt. Take off the flanges of the 3-axis motor and the 3-axis motor together, as shown in Figure 8- 7.

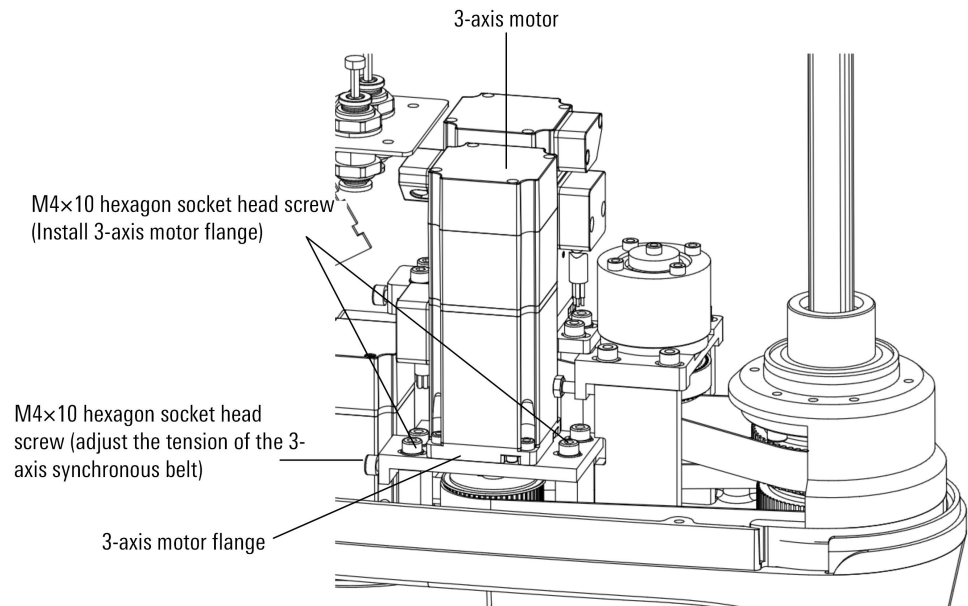

Figure 8- 7 Schematic diagram of disassembling 3-axis motor flange

- Step4. Use an Allen wrench to remove the four M4×10 inner hexagon socket head screws for installing the 4-axis motor flange, and then slowly loosen the a M4×10 inner hexagon socket head screw that adjusts the tension of the 4-axis first-stage timing belt. Take off the flanges of the 4-axis motor and 4-axis motor together, as shown in Figure 8- 8.
- Step5. Use an Allen wrench to unscrew and remove the four M4×12 hexagon socket head screws for installing the intermediate shaft flange, and then use a common wrench to slowly loosen the two M4×12 hexagon head screws that adjust the tension of the 4-axis secondary timing belt. Take off the intermediate axis and the intermediate axis flange together, as shown in Figure 8- 8.

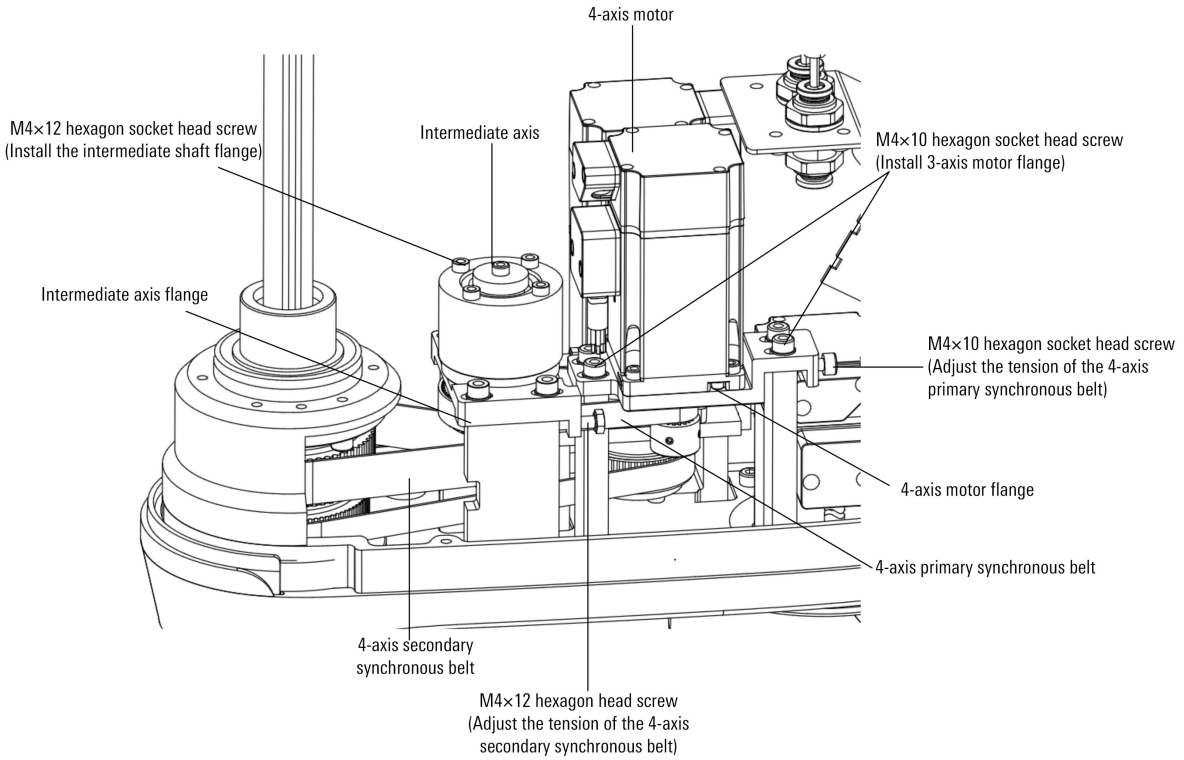

Figure 8- 8 Schematic diagram of disassembling 4-axis motor flange and intermediate axis

Step6. Use an Allen wrench to remove the five M3×35 hexagon socket head screws for mounting the screw spline flange from the lower end of the forearm, and move the screw spline flange upward, as shown in Figure 8- 9.

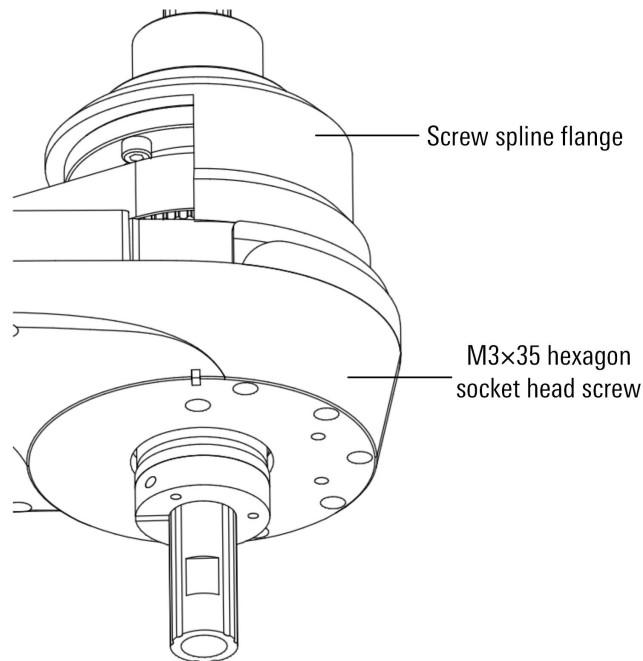

Figure 8- 9 Schematic diagram of disassembling screw spline flange

Step7. Remove the 3-axis timing belt, install a new timing belt, and re-fix the screw flange on the forearm, as shown in Figure 8- 10.

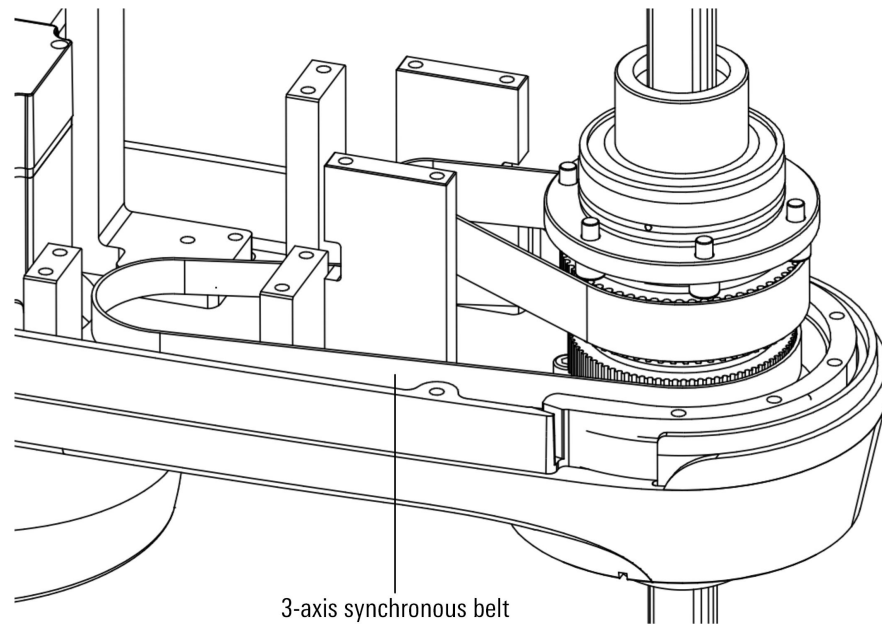

Figure 8- 10 Schematic diagram of replacing the 3-axis synchronous belt

- Step8. Preliminarily install the intermediate shaft pulley assembly, and then adjust the tension parameters of the 4-axis secondary timing belt by rotating the two M4×12 hexagon head screws on the side. It is recommended to use a sonic tension meter to control the tension frequency of the 4-axis secondary timing belt Within the range of 355Hz ~ 372Hz, tighten the four M4×12 hexagon socket head screws for installing the intermediate shaft flange in accordance with the 8.8 torque standard of DIN267.
- Step9. Preliminarily install the 4-axis motor assembly, and then adjust the tension parameters of the 4-axis primary timing belt by rotating a M4×10 hexagon socket head screw on the side. It is recommended to use a sonic tension meter to control the 4-axis primary timing belt tension frequency within the range of 471Hz ~ 494Hz, tighten the four M4×10 hexagon socket head cap screws for mounting the flange of the 4-axis motor according to the 8.8 torque standard of DIN267.
- Step10. Preliminarily install the 3-axis motor assembly, and then adjust the tensioning parameters of the 3-axis synchronous belt by rotating a M4×10 hexagon socket head screw on the side. It is recommended to use a sonic tension meter to control the tension frequency of the 3-axis synchronous belt within the range of 194Hz ~204Hz Inside, tighten the four M4×10 hexagon socket head screws for mounting the flange of the 3-axis motor in accordance with the 8.8 torque standard of DIN267.
- Step11. Install the forearm shell.
- Step12. Carry out the calibration of the J3 and J4 axis of the manipulator. For details, please refer to **Chapter 5** of this manual.

Replace the first-level timing belt of the J4 axis

The replacement process is as follows:

- Step1. Cut off the power to the control device.
- Step2. Use an Allen wrench to remove the ten M3×6 hex socket flat head screws and four M3×30 hex socket head screws that fix the forearm shell, and remove the forearm shell, refer to Figure 8- 11.

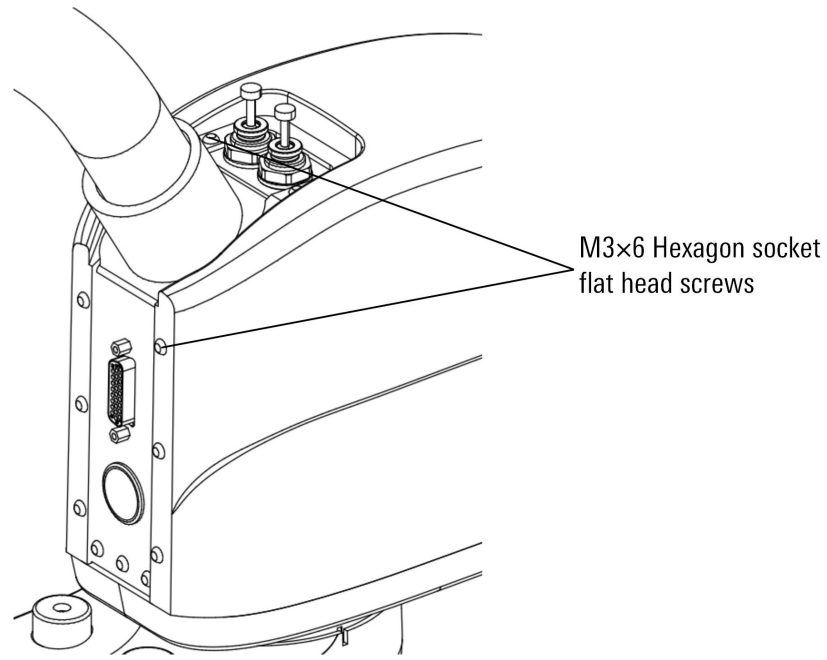

(a) Remove the top and rear screws

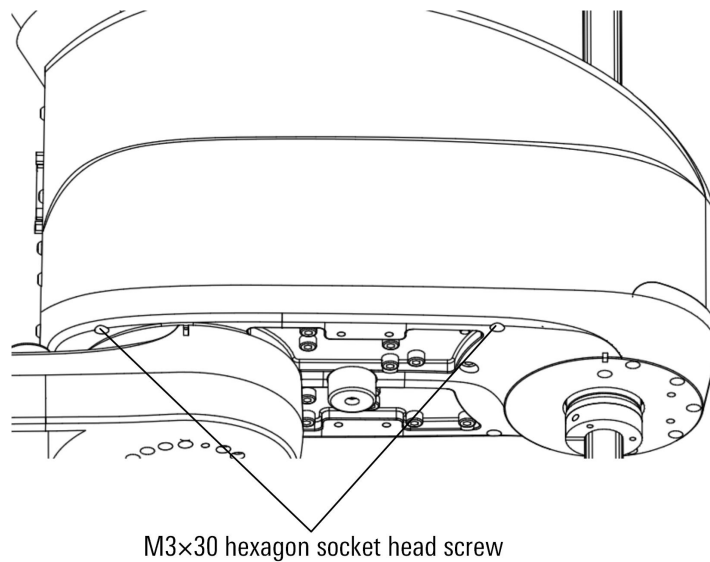

(b) Remove bottom screw

Figure 8- 11 Schematic diagram of removing the screws of the forearm shell

- Step3. Use an Allen wrench to remove the four M4×10 inner hexagon socket head screws for installing the flange of the 4-axis motor, and then slowly loosen the a M4×10 inner hexagon socket head screw that adjusts the tension of the 4-axis primary timing belt. Remove the flanges of the 4-axis motor and 4-axis motor together, as shown in Figure 8- 12.
- Step4. Use an Allen wrench to unscrew and remove the four M4×12 hexagon socket head screws for installing the intermediate shaft flange, and then use a common wrench to slowly loosen the two M4×12 hexagon head screws that adjust the tension of the 4-axis secondary timing belt. Take off the intermediate shaft and the intermediate shaft flange together, as shown in Figure 8- 12.

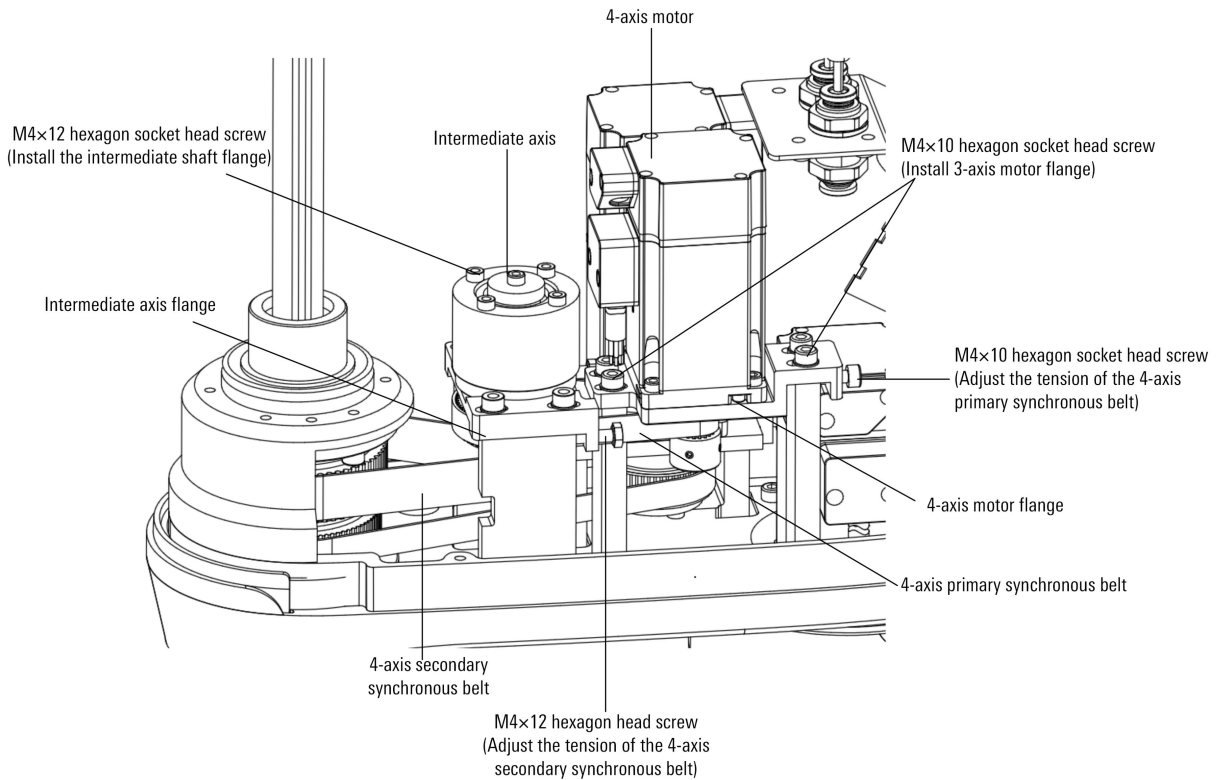

Figure 8- 12 Schematic diagram of disassembling 4-axis motor flange and intermediate shaft

- Step5. Remove the 4-axis primary timing belt, install a new timing belt, and install the secondary timing belt.
- Step6. Preliminarily install the intermediate shaft pulley assembly, and then adjust the tension parameters of the 4-axis secondary timing belt by rotating the two M4×12 hexagon head screws on the side. It is recommended to use a sonic tension meter to control the tension frequency of the 4-axis secondary timing belt within the range of 355~372Hz, tighten the four M4×12 hexagon socket head screws for installing the intermediate shaft flange in accordance with the 8.8 torque standard of DIN267.
- Step7. Preliminarily install the 4-axis motor assembly, and then adjust the tensioning parameters of the 4-axis primary timing belt by rotating a M4×10 hexagon socket head screw on the side. It is recommended to use a sonic tension meter to tighten the 4-axis primary timing belt. Control in the range of 471~494Hz, tighten the four M4×10 hexagon socket head screws for mounting the flange of the 4-axis motor in accordance with the 8.8 torque standard of DIN267.
- Step8. Install the forearm shell.
- Step9. Carry out the calibration of the J4 axis of the manipulator. For details, see *Chapter 5* of this manual.

Replace the secondary timing belt of the J4 axis

The replacement process is as follows:

- Step1. Cut off the control device power
- Step2. Use an Allen key to remove the ten M3×6 hexagon socket flat head screws and four M3×30 hexagon socket head screws that fix the forearm shell, and remove the forearm shell. Refer to Figure 8- 11.

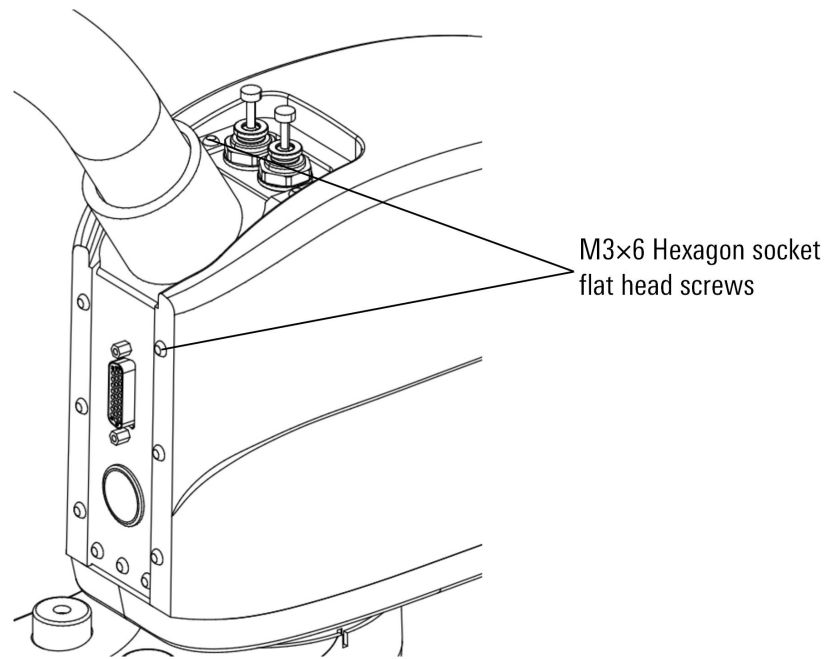

(a) Remove the top and rear screws

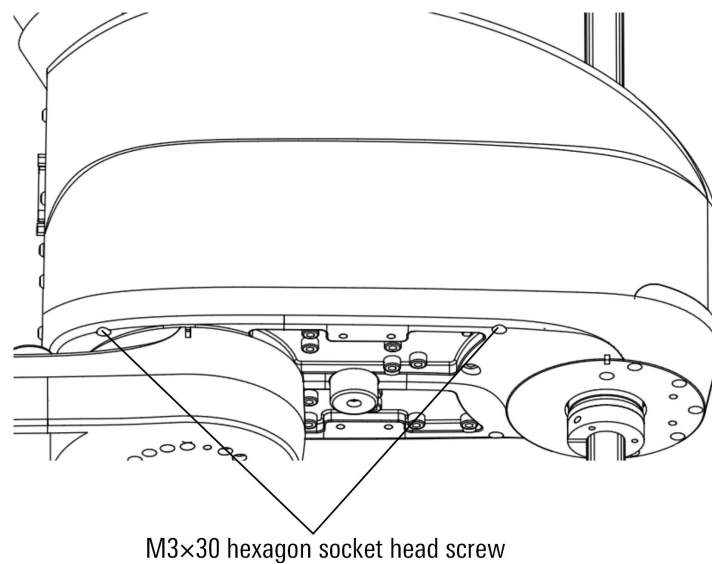

(b) Remove bottom screw

Figure 8- 13 Schematic diagram of removing the screws of the forearm shell

- Step3. Use an Allen wrench to remove the four M4x10 inner hexagon socket head screws for installing the flange of the 4-axis motor, and then slowly loosen the a M4x10 inner hexagon socket head screw that adjusts the tension of the 4-axis primary timing belt. Remove the flanges of the 4-axis motor and 4-axis motor together, as shown in Figure 8- 14.
- Step4. Use an Allen wrench to unscrew and remove the four M4x12 hexagon socket head screws for installing the intermediate shaft flange, and then use a normal wrench to slowly loosen the two M4x12 hexagon heads screws that adjust the tension of the 4-axis secondary timing belt. Take off the intermediate axis and the intermediate axis flange together, and take off the 4-axis primary timing belt, as shown in Figure 8- 14.

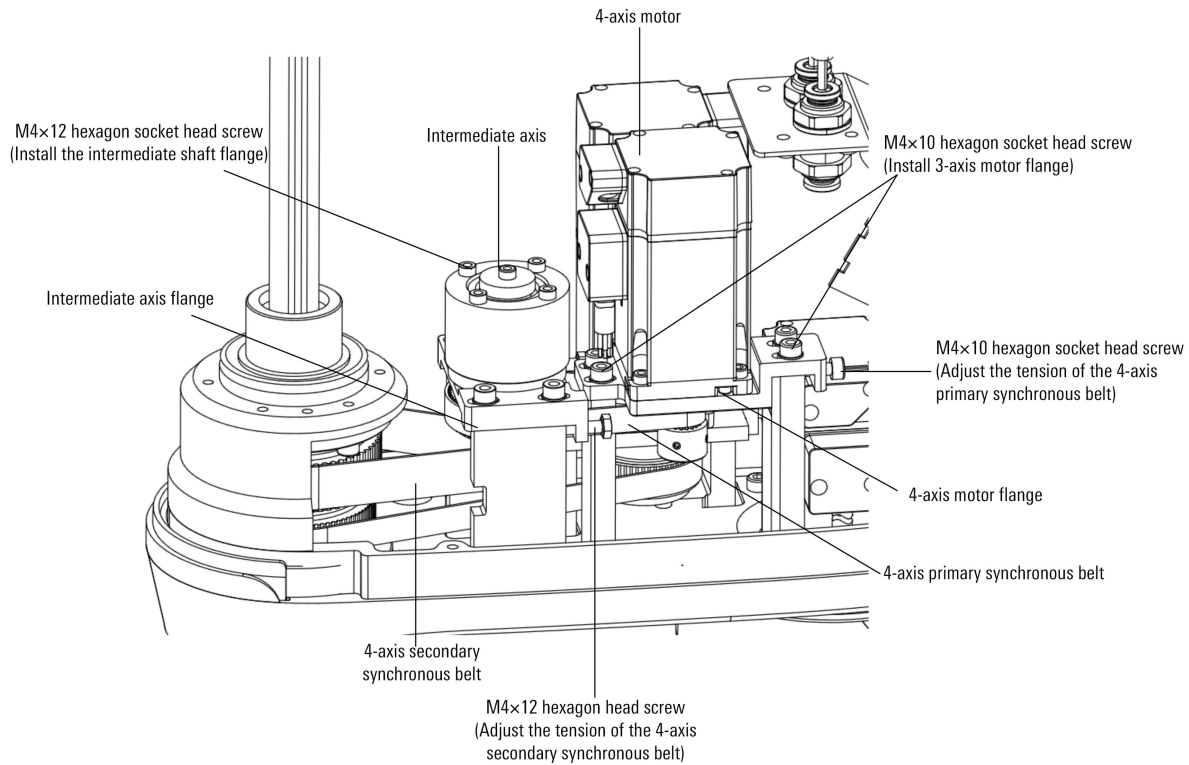

Figure 8- 14 Schematic diagram of disassembling the intermediate axis

Step5. Use an Allen wrench to remove the five M3×35 hexagon socket head screws for installing the screw spline flange from the lower end of the forearm, move the screw spline flange upward, and remove the fixed screw spline method from the lower end of the forearm. The five M3 screws used for the flange are shown in Figure 8- 9, and the screw spline flange is removed upward, as shown in Figure 8- 15.

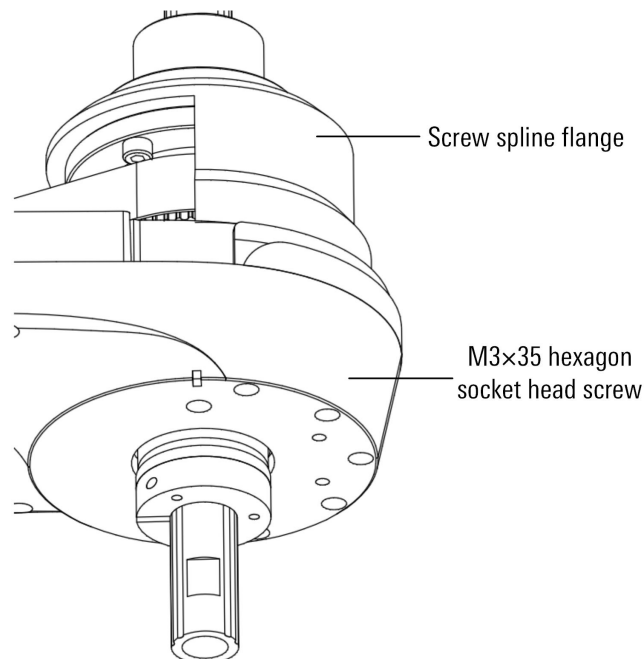

Figure 8- 15 Schematic diagram of disassembling screw spline flange

Step6. Remove the 4-axis secondary timing belt, install a new timing belt, and install other timing belts, as shown in Figure 8- 16, and then re-fix the screw spline flange to the forearm.

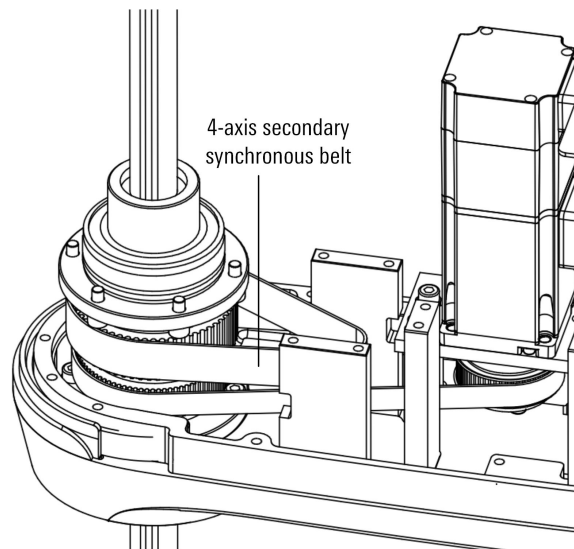

Figure 8- 16 Schematic diagram of disassembling 4-axis secondary synchronous belt

- Step7. Preliminarily install the intermediate shaft pulley assembly, and then adjust the tension parameters of the 4-axis secondary timing belt by rotating the two M4×12 hexagon head screws on the side. It is recommended to use a sonic tension meter to control the 4-axis secondary timing belt tension frequency within the range of 355Hz~372Hz, tighten the four M4×12 hexagon socket head screws for installing the intermediate shaft flange in accordance with DIN267's 8.8 torque standard.
- Step8. Preliminarily install the 4-axis motor assembly, and then adjust the tensioning parameters of the 4-axis primary timing belt by rotating a M4×10 hexagon socket head screw on the side. It is recommended to use a sonic tension meter to tighten the 4-axis primary timing belt. Control in the range of 471Hz ~494Hz, tighten the four M4×10 hexagon socket head screws for mounting the flange of the 4-axis motor in accordance with the 8.8 torque standard of DIN267.
- Step9. Install the forearm shell.
- Step10. Calibrate the J4 axis of the manipulator. For details, see Chapter 5 of this manual.

9. Fault finding, diagnosis and repSOT

The malfunction of the manipulator is sometimes caused by multiple different reasons. It is often difficult to thoroughly investigate the cause. If the error handling method is adopted, the malfunction may be further deteriorated. Therefore, it is very important to analyze the malfunction in detail and find the real cause.

The possible faults and causes of the manipulator are shown in Table 9- 1-Table 9- 7. If you are not sure of the cause or how to deal with it, please contact our company.

Table 9- 1 Possible faults and causes of manipulator

Fault	Classification	Possible Causes	Treatment
	<p>When the manipulator operates, its base floats from the workshop pedestal</p> <p>There is a gap between the base and workshop pedestal</p> <p>The screws connecting the base and workshop pedestal are loose</p>	<p>Fixation of Base:</p> <ol style="list-style-type: none"> 1. The manipulator base is not firmly fixed on the workshop pedestal 2. The base floats from the workshop pedestal and generates the vibration when the manipulator acts due to the screw looseness, insufficient flatness of base and the foreign objects. 	<ol style="list-style-type: none"> 1. When the screw is loose, tighten it with the torque wrench according to the proper torque 2. Trim the base flatness in accordance with the tolerance 3. Check if the foreign matters are trapped, and if so, remove them 4. Please consult with us
<p>Vibration</p> <p>Abnormal noise</p>	<p>Workshop pedestal vibrates when the manipulator acts</p>	<p>Workshop Pedestal:</p> <ol style="list-style-type: none"> 1. Pedestal is not completely fixed on the foundation. Therefore, the workshop pedestal vibrates when the manipulator acts. 2. The insufficient rigidity of workshop pedestal, and the reaction force and torque generated by the manipulator cause the deformation and vibration. 	<ol style="list-style-type: none"> 1. Completely fix the workshop pedestal according to the corresponding method 2. Workshop pedestal shall be processed to improve its rigidity 3. For the workshop pedestal with machining difficulty, the vibration may be mitigated through the modification of moving program 4. Please consult with us

Table 9- 2 Possible Faults and Causes of Manipulator

Fault	Classification	Possible Causes	Treatment
<p>Vibration</p> <p>Abnormal noise</p>	<p>Vibration at a specific posture during the action</p> <p>No vibration at the slow action</p> <p>Obvious vibration during acceleration and deceleration</p> <p>Simultaneous vibration of multiple axes</p>	<ol style="list-style-type: none"> 1. Load of manipulator exceeds the allowable value 2. Action procedures are too strict on the manipulator 3. Improper acceleration 	<ol style="list-style-type: none"> 1. Confirm whether the manipulator load exceeds the allowable value, and reduce the load or change the action procedures 2. Mitigate the specific vibrations by reducing speed, reducing acceleration and changing the action procedures
	<p>Collision or long-term overload operation of manipulator</p> <p>No replacement of lubricating grease for a long time</p>	<ol style="list-style-type: none"> 1. Mechanical transmission system is subjected to excessive external force due to collision or overload, causing the damage to the gear surface or rolling surface of the gear, bearing, reducer or the peeling due to fatigue 2. The gear surfaces or rolling surfaces of gear, bearing and reducer are damaged due to the foreign matters trapped in the gear, bearing or reducer. 3. The gear surfaces or rolling surfaces of gear, bearing and reducer peel off due to fatigue because of no replacement of lubricating grease for long term 4. The above reasons may cause the periodic vibration or abnormal noise 	<ol style="list-style-type: none"> 1. Make the manipulator operate uniaxially to confirm the Joint that produces the vibration and noise 2. If you need to replace the gear, bearing and reducer, please contact us. 3. Do not use the manipulator at overloaded status 4. If you need to replace the lubricating grease, please contact us. 5. Please consult with us

Table 9- 3 Possible Faults and Causes of Manipulator

Fault	Classification	Possible Causes	Treatment
<p>Vibration Abnormal noise</p>	<p>Causes may not be determined mechanically</p>	<ol style="list-style-type: none"> 1. Fault of the circuit inside the controller, failure of command to transmit to the motor, or the motor information not correctly transmitted to the controller 2. Fault of pulse encoder and the position of motor not correctly transmitted to the controller 3. Failure of motor body to perform its original functions 4. Breakage of internal motor cable of manipulator causes the command not to be correctly transmitted to the motor and control system 5. Voltage drop and no guarantee for the specified voltage 6. Incorrect control parameters are input 	<ol style="list-style-type: none"> 1. For the fault of controller, see the controller manual 2. Replace the motor of vibrating Joint to confirm whether it vibrates 3. Check the cables of the manipulator body, between the manipulator body and control cabinet, and inside the controller for damage, and if so, replace the cable. 4. Check whether the cable joint is in good contact. In case of the poor contact or looseness, re-tighten or take appropriate measures to ensure the good contact. 5. Check whether the action control parameters are correct, and if not, re-enter the correct parameters. 6. Please consult with us
	<p>The mechanical action near the manipulator is closely related to the vibration of robot.</p>	<ol style="list-style-type: none"> 1. Mechanical electrical noise from the manipulator 2. If the grounding wire is not connected properly, the electrical noise will mix into the grounding wire, causing the vibration of manipulator due to the interference with command 3. Poor connection of grounding wire will lead to the unstable grounding, causing the vibration of manipulator due to electrical noise interference. 	<ol style="list-style-type: none"> 1. Connect the grounding wire properly to avoid the electrical noise mixed into the manipulator 2. Please consult with us

Table 9- 4 Possible Faults and Causes of Manipulator

Fault	Classification	Possible Causes	Treatment
<p>Vibration Abnormal noise</p>	<p>Abnormal noise after the replacement of lubricating grease Abnormal noise occurs during the operation of robot after a long-term shutdown Abnormal noise at low speed</p>	<p>1. Abnormal noise from the manipulator at low speed immediately after the replacement or at the restart after the long-term shutdown.</p>	<p>1.Observe the operation of manipulator for 1-2 days. Usually the abnormal noise will disappear.</p>
<p>Shake of manipulator</p>	<p>After power-off, some parts of manipulator may be shaken manually. There is a gap between the connecting surfaces of manipulator</p>	<p>1. Manipulator bolts are loose 2. Connecting bolts on the manipulator are loose due to the overload, collision, etc., thus resulting in the shake</p>	<p>For each Joint, check if the bolts at the following parts are loose. If so, tighten it with a torque wrench according to a suitable torque.</p> <ol style="list-style-type: none"> 1. Fixing bolts of motor 2. Fixing bolts of reducer shell 3. Fixing bolts of output shaft of reducer 4. Fixing bolts of pedestal 5. Fixing bolts between arms 6. Fixing bolts of shell 7. Fixing bolts of end effector
	<p>Turn off the power of manipulator, and confirm that the screws are tightened, and shake the entire head of manipulator manually</p>	<p>1. Large backlash is resulted from the wear or damage of internal gears of manipulator due to the overload, collision, etc.</p>	<p>1. If you need to replace the internal gear, please consult with us</p>

Table 9- 5 Possible Faults and Causes of Manipulator

Fault	Classification	Possible Causes	Treatment
Motor overheating	<p>Ambient temperature rise for installation of manipulator, and the overheating of motor</p> <p>Motor overheats after the cover plate is mounted on the motor</p> <p>Motor overheats after the action procedures of manipulator and load conditions are changed</p>	<p>Ambient Temperature :</p> <p>1. Ambient temperature rise or the deterioration of heat dissipation of motor after the cover plate is installed</p> <p>Load Action:</p> <p>1. Current value of motor exceeds its rated value due to the load and operating procedures</p>	<p>1. Decrease of ambient temperature may prevent the motor from overheating</p> <p>2. Improvement of ventilation conditions around the motor, i.e. the heat dissipation of motor, may effectively prevent the motor from overheating.</p> <p>3. A radiation shielding plate if there is a heat source around the motor may prevent the motor from overheating.</p> <p>4. Slowing down the action procedures and reducing the load may decrease the average current value of motor, thus preventing the motor from overheating.</p> <p>5. Please consult with us</p>
	<p>Motor overheats after the action control parameters of manipulator are changed</p>	<p>Control Parameter:</p> <p>1. Improper input parameters will cause the incorrect acceleration and deceleration of robot, so that the average current value of increases.</p>	<p>1. Enter the appropriate parameters according to the relevant instructions.</p> <p>2. Please consult with us</p>
	<p>Motor overheats due to the causes other than above ones</p>	<p>Mechanical Fault of Manipulator:</p> <p>1. Mechanical system fault of manipulator causes the overload of motor</p> <p>Motor fault:</p> <p>1. Brake fault causes the motor to always operate when the brake is applied, which causes the motor to withstand excessive load</p> <p>2. Failure of motor body to perform its functions causes the excessive current to flow through the motor</p>	<p>1. Please rectify the mechanical fault by reference to the instructions of vibration, abnormal noise and looseness.</p> <p>2. Please confirm whether the brake is released when the motor is powered on.</p> <p>3. After the motor is replaced, the overheating of motor disappears. It is confirmed that the this condition is abnormal.</p> <p>4. Please consult with us</p>

Table 9- 6 Possible Faults and Causes of Manipulator

Fault	Classification	Possible Causes	Treatment
Leakage of lubricating grease	Lubricating grease leaks out from the mechanical part	<p>Poor Sealing:</p> <ol style="list-style-type: none"> 1. Crack of casting due to the excessive external force caused by the collision 2. Damage of O-ring during the disassembly and reassembly 3. Scratch of oil seal due to the dust intrusion 4. Poor sealing between the cover plate and casting 	<ol style="list-style-type: none"> 1. In case of casting crack, etc., the sealant may be used to block the lubricating grease as an emergency measure, but in view of the further extension of crack, the part shall be replaced as soon as possible. 2. Please consult with us
Falling of manipulator Joint	<p>The brake is completely ineffective and the Joint falls quickly</p> <p>After the brake is contracted, the shaft falls slowly</p>	<ol style="list-style-type: none"> 1. The damage of brake drive relay causes the brake to always be powered on and not to work. 2. Wear and damage of brake body affect the braking effect. 3. The lubricating oil and grease inside the motor cause the brake to slip. 	<ol style="list-style-type: none"> 1. Check if the brake drive relay is damaged, and if so, replace the relay 2. In case of the wear of brake, the damage of brake body and the lubricating grease inside the motor, replace the motor. 3. Please consult with us

Table 9- 7 Possible Faults and Causes of Manipulator

Fault	Classification	Possible Causes	Treatment
Position offset	<p>Manipulator deviates from the teaching position</p> <p>The repeated positioning accuracy of manipulator is greater than the allowed value</p>	<p>Mechanical Fault:</p> <ol style="list-style-type: none"> 1. The unstable repeated positioning accuracy may be caused by the mechanical system abnormality, screw looseness, etc. 2. The repeated positioning accuracy keeps stable after the deviation; the joint surface of pedestal surface, Joint casting and reducer may slide due to the excessive load such as the collision. 3. Abnormality of motor encoder 	<ol style="list-style-type: none"> 1. In case of the unstable repeated positioning accuracy, please rectify the mechanical fault by reference to the instructions for the vibration, abnormal noise and shaking. 2. If the repeated positioning accuracy keeps stable, please modify the teaching program. If the collision does not occur again, the deviation may be avoided. 3. In case of the abnormality of motor encoder, replace the motor or encoder. 4. Please consult with us

Fault	Classification	Possible Causes	Treatment
	Position only deviates from the specific peripheral equipment	Deviation of Peripheral Equipment 1. The external equipment under the external force leads to the deviation relative to the manipulator	1. Please relocate the peripheral equipment 2. Please modify the teaching program 3. Please consult with us
	Deviation occurs after the modification of parameters	Parameters: 1. The modification of calibration data causes the loss of manipulator origin	1. Re-enter the previous correct calibration data 2. In case of uncertain calibration data, please recalibrate the manipulator 3. Please consult with us

Appendix A type manipulator regular maintenance table

Appendix A Periodic Maintenance Schedule of Manipulator

Item	Mainten ance cycle	First Maintenance 320h	3 months 960h	6 months 1,920h	9 months 2,880h	1 year 3,840h	15 months 4,800h	18 months 5,760h	21 months 6,720h	2 year 7,680h	27 months 8,640h	30 months 9,600h	33 months 10,560h	3 year 11,520h	39 months 12,480h	42 months 13,440h	45 months 14,400h	4 year 15,360h	51 months 16,320h	54 months 17,280h	57 months 18,240h	5 year 19,200h
1	Cleaning of manipulator	0.5h	○	○	○	○	○	○	○	○	○	○	○	○	○	○	○	○	○	○	○	○
2	Cleaning of control cabinet vent	0.1h	○	○	○	○	○	○	○	○	○	○	○	○	○	○	○	○	○	○	○	○
3	Wether the synchronous belt worn	0.5h	○	○	○	○	○	○	○	○	○	○	○	○	○	○	○	○	○	○	○	○
4	Check the manipulator cable for damage	3h	○	○	○	○	○	○	○	○	○	○	○	○	○	○	○	○	○	○	○	○
5	Check the manipulator cable sheath for damage	2h	○	○	○	○	○	○	○	○	○	○	○	○	○	○	○	○	○	○	○	○
6	Check the connecting cable of teach pendant, control cabinet and manipulator for damage	0.2h	○	○	○	○	○	○	○	○	○	○	○	○	○	○	○	○	○	○	○	○

Item	Mainten ance cycle	First Maintenance 320h	3 months 960h	6 months 1,920h	9 months 2,880h	1 year 3,840h	15 months 4,800h	18 months 5,760h	21 months 6,720h	2 year 7,680h	27 months 8,640h	30 months 9,600h	33 months 10,560h	3 year 11,520h	39 months 12,480h	42 months 13,440h	45 months 14,400h	4 year 15,360h	51 months 16,320h	54 months 17,280h	57 months 18,240h	5 year 19,200h
7	Check the connectors of motor, etc. for looseness	0.2h	○			○				○				○				○				○
8	Tighten the end effector screws	0.2h	○			○				○				○				○				○
9	Tighten the external main screws	1h	○			○				○				○				○				○
10	Check the end effector cable for damage	0.2h	○			○				○				○				○				○
11	Check the limit rubber block for damage	0.1h	○			○				○				○				○				○
12	Replacement of Synchronous Belt	1h				○				○				○				○				○
13	Battery Replacement	0.5h								○								○				
14	Replace the internal cables of manipulator	8h																○				
15	Manipulator overhaul																					○

Item	Mainten- ance cycle	First Maintenance 320h	3 months 960h	6 months 1,920h	9 months 2,880h	1 year 3,840h	15 months 4,800h	18 months 5,760h	21 months 6,720h	2 year 7,680h	27 months 8,640h	30 months 9,600h	33 months 10,560h	3 year 11,520h	39 months 12,480h	42 months 13,440h	45 months 14,400h	4 year 15,360h	51 months 16,320h	54 months 17,280h	57 months 18,240h	5 year 19,200h
Note: ○ indicates that maintenance is required																						

Appendix B Table of screw strength and tightening torque (Nm)

Appendix B Table of screw strength and tightening torque (Nm)

Thread specification	Performance level		
	8.8 level	10.9 level	12.9 level
M2	0.35	0.48	0.56
M2.5	0.68	0.93	1.1
M3	1.2	1.6	2
M4	2.8	3.7	4.4
M5	5.6	7.5	9
M6	9.5	12.5	15
M8	23	31	36
M10	45	60	70
M12	78	104	125
M14	113	165	195
M16	195	250	305
M20	370	500	600



Prompt

All screws must be tightened with proper torque.

Except for the torque specified in the text, the corresponding tightening torque shall be selected according to the screw performance level.

Remove foreign matters in screws and threaded holes.

Torque for lightly lubricated screws.

Screws shall be tightened evenly and symmetrically.

According to the installation requirements of the reducer and other moving parts, apply thread adhesive to the engagement part of some screws.

ligent | LIGENT TECH CO., LTD



Website



YouTube

Official Website: <http://ligentrobot.com>
E-Mail: info@sotrobot.com
whatsapp: +86-13551010933

The introduction of the products is only for reference, the products and services delivered shall be subject to the specific contract.