

# Operation Manual

V1.0.0

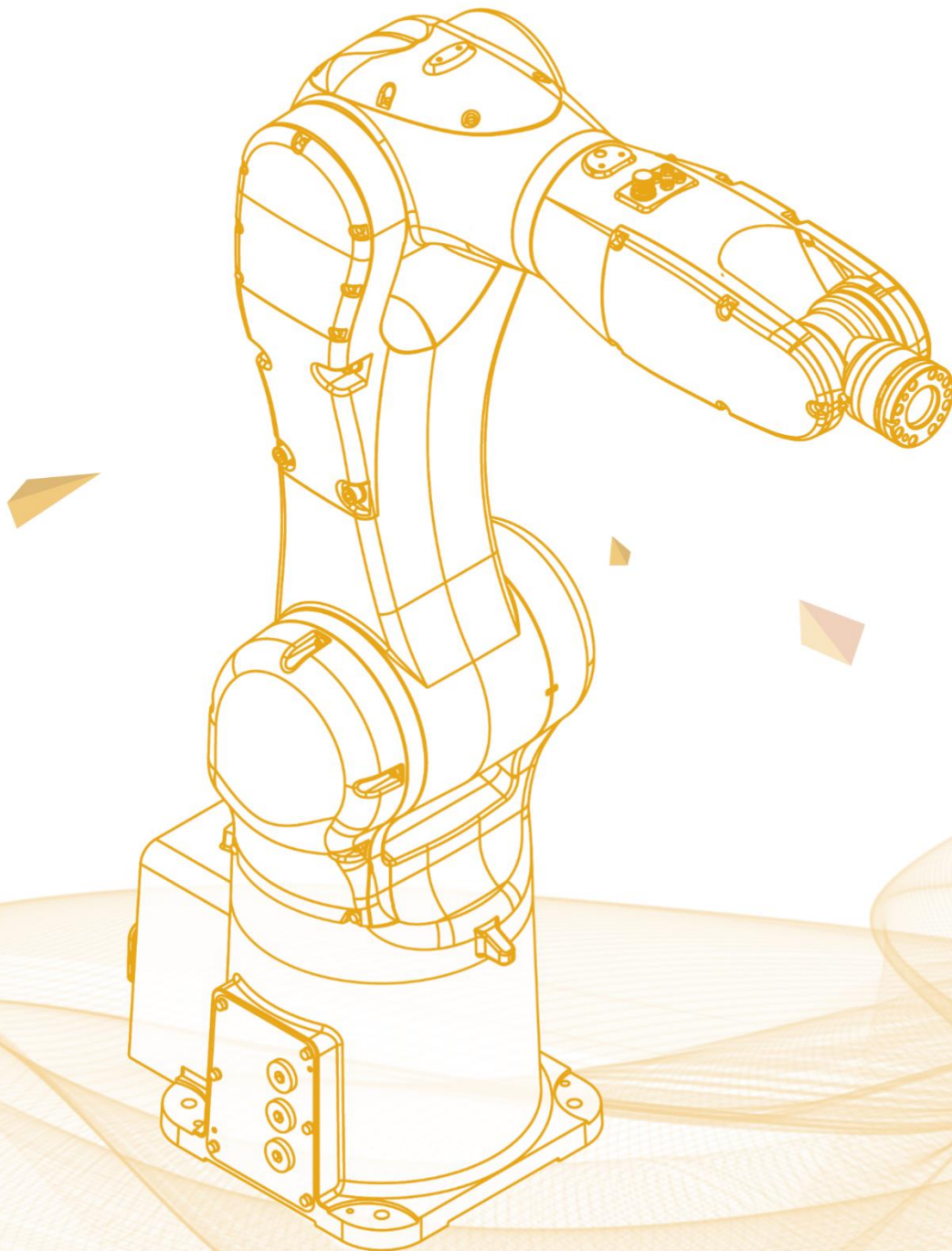

# Foreword

---

## About this manual

This manual is for technicians to install, use, and use the industrial robot quickly, correctly, and safely, to be familiar with the relevant precautions, and to perform regular routine maintenance work on the manipulator.

## Prerequisites

Before operating the robot, be sure to read the relevant safety instructions and operation instructions of the product carefully. Users must understand the safety knowledge and basic operation knowledge before using the robot.

Please read the following documents when necessary:

- "inCube20 Control Cabinet Manual"
- "SOT-TP teach pendant operation manual"
- "ARL Programming Manual"
- "Industrial Robot System Quick Start Manual"



## Target groups



- Operators
- Product technicians
- Technical service personnel
- Robot teachers

## Meaning of common signs

The signs and their meanings in this manual are detailed in Table 1.

**Table 1 Signs used in this manual**

Sign	Meaning
 Danger	Failure to follow the instructions may result in an accident causing the severe or fatal injury or the great losses of property.
 Warning	Failure to follow the instructions may result in an accident causing the severe or fatal injury or the great losses of property.

Sign	Meaning
 Caution	Prompt for the environmental conditions and important things or shortcuts you shall pay attention to
 Prompt	Prompt for additional literature and instructions for additional information or more detailed operating instructions

### Manual description

The contents of this manual are subject to supplementation and modification. Please visit "Download Center" on the website regularly to obtain the latest version of this manual in a timely manner.

Website URL: <http://ligentrobot.com/>

### Revision history

The revision history contains the instructions for each document update. The latest version of the document contains updates to all previous versions of the document.

**Table 2 Signs used in this manual**

Version	Publication date	Modification description
V1.0.0	2020.04.30	1st official publication

### Manual Number and Version

The manual-related information is shown in Table 3.

**Table 3 Document-related information**

Document name	"Industrial Robot Manipulator Manual"
Document number	UM-P05310000032-001
Document version	V1.0.0

### Declaration of applicable with product standards

The requirements for industrial robot system design are detailed in Table 4.

**Table 4 Declaration of applicable safety standards**

<b>Standard</b>	<b>Description</b>	<b>Version</b>
2006/42/EC	<b>Machinery directive :</b> Machinery directive 2006/42/EC (new version) issued by European Parliament and Council on May 17, 2006 to modify 95/16/EC	2006
2014/30/EU	<b>Electromagnetic compatibility directive:</b> 2014/30/EU directive issued by European Parliament and Council on February 26, 2014 to balance the electromagnetic compatibility regulations of member states	2014
2014/68/EU	<b>Pressure facility directive:</b> Electromagnetic compatibility directive: 2014/68/EU directive issued by European Parliament and Council on May 15, 2014 to balance the pressure facility regulations of member states  (It is only suitable for the robot with hydraulic balance weight)	2014
ISO 13850	<b>Safety of machinery:</b> Emergency stop function - Principles for design	2015
ISO 13849-1	<b>Safety of machinery:</b> Safety-related parts of control systems - Part 1: General principles for design	2015
ISO 12100	<b>Safety of machinery:</b> General principles for design - Risk assessment and risk reduction	2010
ISO 10218-1	<b>Robots and robotic devices - Safety requirements for industrial robots :</b> Part 1: Robots  (Prompt: Information is consistent with ANSI/RIAR.15.06-2012, Part 1)	2011
61000-6-2	<b>Electromagnetic compatibility (EMC):</b> Part 6-2: Generic standards - Immunity for industrial environments	2005
61000-6-4 + A1	<b>Electromagnetic compatibility (EMC):</b> Part 6-4: Generic standards - Emission standard for industrial environments	2011
60204-1 + A1	<b>Safety of machinery:</b> Electrical equipment of machines - Part 1: General requirements	2009
IEC 60529	<b>IP rating provided by enclosures (IP Code):</b> This standard applies to the IP rating for the electrical equipment with enclosures and the rated voltage exceeding 72.5kv.	2001

## General safety description

---

Thank you for purchasing our manipulator. This description is required for the safe use of the manipulator. before using the operator, please read the manual carefully and use the manipulator correctly on the premise of understanding it.

For the detailed functions of the manipulator, please fully understand its specifications through the relevant instructions.

### Safety considerations

In general, the manipulator cannot be operated by a single operation, and only install the end effector, and the frame functions as the peripheral equipment and the system to perform the operation.

When considering its security, the manipulator should not be considered independently, but should be considered in the system environment.

When using the manipulator, be sure to take corresponding measures to the safety fence.

### WARNING, CAUTION AND PROMPTS.

This specification includes matters needing attention to ensure the personal safety of operators and prevent damage to operators. According to their safety importance, they are described as "warning" and "caution" in this paper, and the supplementary instructions are described as "prompts".

Before using the operator, the user must read these "warnings ", " cautions" and "prompts ".



Warning



In the case of an incorrect operation, it is possible to cause death or serious injury to the operator or other operator.



Caution

If the operation is wrong, it may cause the operator or other operator to slightly injure or damage the equipment.

### General considerations

 Warning	<ul style="list-style-type: none"> <li>■ When connecting or disconnecting related peripheral devices (such as safety fences, etc.) and various signals of the manipulator, be sure to confirm that the manipulator is in a stopped state to avoid incorrect connections.</li> <li>■ Do not use the operator in the situation shown below. Otherwise, it will not only have a negative impact on operators and peripherals, but also cause casualties.                         <ul style="list-style-type: none"> <li>● Used in flammable environments.</li> <li>● Used in explosive environments.</li> <li>● Used in environments where there is a lot of radiation.</li> <li>● Used in water or in high humidity environments.</li> <li>● Used for the purpose of transporting people or animals.</li> <li>● Use as a foot (e.g., on or depending on the operator)</li> </ul> </li> <li>■ Operators who use the operator should wear the safety appliances shown below before carrying out their work.                         <ul style="list-style-type: none"> <li>● Work clothes suitable for the job content</li> <li>● Safety shoes</li> <li>● Safety helmet</li> </ul> </li> </ul>
 Prompt	<p>Personnel who carry out programming and maintenance operations must receive appropriate training through the relevant training of the company.</p>

**Considerations during installation**

 Warning	<ul style="list-style-type: none"> <li>■ When handling and installing the machines, they must be carried out correctly according to the method shown in our manual. If the operation is carried out in the wrong way, it is possible that the operator will be killed or injured due to the overturning of the operator.</li> <li>■ When using the operator for the first time after installation, be sure to do so at a low speed, and then gradually accelerate the speed and confirm that there are any anomalies.</li> </ul>
--	--

**Matters needing attention in operation**

 Warning	<ul style="list-style-type: none"> <li>■ When using the operator, be sure to make sure there are no personnel in the safety fence before carrying out the operation. At the same time, check to see if there is a potential danger, and when it is confirmed that there is a potential danger, be sure to eliminate the danger before carrying out the operation.</li> <li>■ When using the instruction device, because there may be errors in the operation of wearing gloves, it is important to take off the gloves before carrying out the work.</li> </ul>
--	---



Prompt

Information such as programs and system variables can be stored in storage media such as memory cards. In order to prevent data loss caused by unexpected accidents, it is recommended that users back up data regularly.

### Considerations in programming



Warning

- When programming, try to do it outside the safety fence., the following matters shall be taken into account when the safety fence needs to be carried out as a last resort:
  - Check the safety fence carefully and make sure it is not dangerous before entering the fence.
  - The emergency stop button can be pressed at any time.
  - The manipulator shall be operated at low speed
  - The operation should be carried out after confirming the state of the whole system, so as to avoid the operator falling into a dangerous situation due to the remote control instructions or actions for the peripheral equipment.



Caution

After the program is finished, it is important to perform the test operation in accordance with the specified procedure. At this time, the operator must operate outside the safety fence.



Prompt

For operators who are programmed, it is important to receive appropriate training through the company.

### Attention should be paid to maintenance work



Warning

- When switching on the power supply, part of the maintenance operation is in danger of electric shock, as far as possible, the maintenance operation should be carried out in the state of power off; professional maintenance personnel should be designated according to the need to carry out maintenance operation; other personnel should be avoided to turn on the power supply when maintaining the operation; even if the power supply must be turned on before the operation can be carried out, the emergency stop button should be pressed and then the operation should be carried out.
- Please consult our company when you need to replace the parts.
- The replacement of parts by the client may result in unexpected accidents, which may cause the operator to be damaged and the operator is injured.
- When entering the security fence, check the whole system carefully and make sure it is not dangerous. If there is a dangerous situation and have to enter the fence, you must grasp the state of the system and be very careful.
- If you need to replace the parts, be sure to use our specified parts. If you use a part other than the specified part, it may cause damage to the operator.
- When removing the motor and brake, the crane hoisting and other

measures should be taken to remove the motor and brake, so as to avoid the falling of the manipulator arm.

- When carrying out maintenance operations, when it is necessary to move the operator as a last resort, the following matters should be taken into account:
  - It is important to ensure that the escape channel is smooth and that the operation should be carried out again under the operation of the whole system in order to avoid blockage of the retreat by the operator and peripherals.
  - Always pay attention to the danger around you and be prepared so that you can press the emergency stop button at any time when you need it.
- The auxiliary equipment such as the crane shall be used when the moving motor and the speed reducer and the like have certain weight parts, so as to avoid the excessive work load for the operators. At the same time, it is necessary to avoid the wrong operation, otherwise, the operation and death of the operation may be caused.
- Be careful not to fall because of the lubricating oil that falls on the ground, wipe the lubricating oil that falls on the ground as soon as possible, and eliminate the possible danger.
- Do not place any part of the body on any part of the manipulator during the operation, and it is prohibited to climb on the manipulator , so as to avoid unnecessary personal injury or adverse effect on the manipulator .
- The following parts will be hot and need attention. When you have to touch the equipment when you have to touch it in the event of heat, you should prepare protective appliances such as heat-resistant gloves:
  - Servo motor
  - reducer
  - Adjacent to motor / reducer
  - Inside the control cabinet
- The parts (such as screws, etc.) removed during the replacement of the parts should be correctly loaded back to their original parts, and if the parts are found to be insufficient or surplus, they should be reconfirmed and installed correctly.
- During the maintenance of the pneumatic system and hydraulic system, it is important to release the internal pressure to zero and operate again.
- After replacing the parts, be sure to carry on the test operation according to the prescribed method. At this point, the operator must operate outside the safety fence.
- After the maintenance operation, the grease, debris and water sprinkled on the ground around the operator and inside the safety fence should be thoroughly cleaned.
- When replacing parts, dust and other foreign bodies should be prevented from entering the manipulator.
- Operators who carry out maintenance and repSOT operations must receive the training of the company and pass the relevant assessment.
- When carrying out maintenance operations, appropriate lighting



appliances should be equipped, but care should be taken not to make the lighting appliances a source of new danger.

- Be sure to refer to this specification for regular maintenance, if not regular maintenance, will affect the service life of the operator, and may lead to accidents.

## Safety protection measures before use

---

Before operating the manipulator and peripheral equipment and the manipulator system composed of them, the safety precautions of the operators and the system must be fully studied. Figure 1 is a schematic diagram of the safe work of industrial robots.

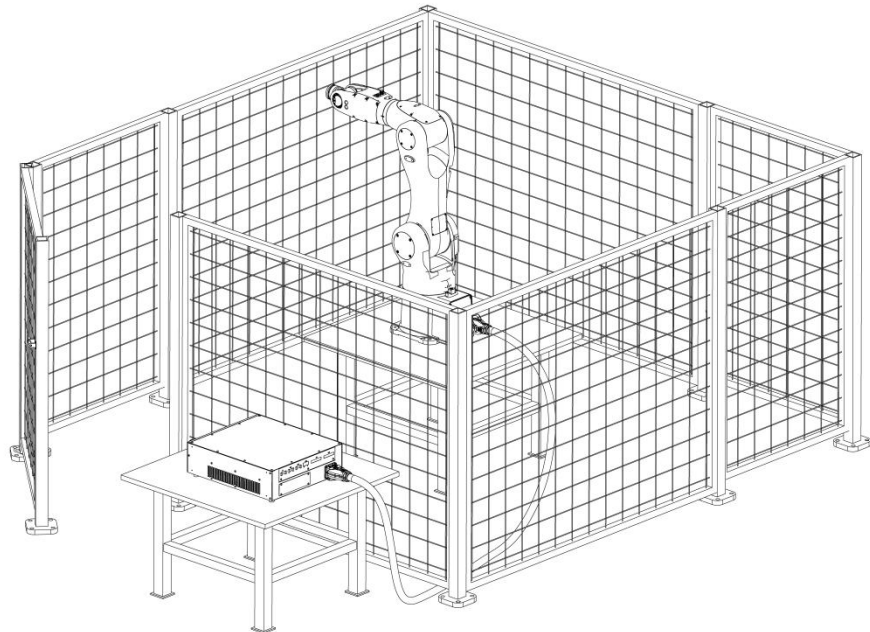

Figure 1 Schematic diagram of safe work of industrial robots

### Definition of operating personnel

Manipulator operation personnel consist of operator, teacher and maintenance engineer who shall satisfy the following conditions:

#### Operator

- Switch on/off the power supply of manipulator.
- Start the manipulator program via the operating panel.
- have no right to operate within the safety barrier

#### Teacher

- Execute the functions of operator.
- Perform the manipulator teaching, etc. outside the safety barrier.

#### Maintenance Engineer

- Execute the functions of teacher.
- Perform the maintenance (repSOT, adjustment, replacement, etc.) of manipulator.

### Safety of operation personnel

Operator, teacher and maintenance engineer shall carefully perform the operation, programming and maintenance of manipulator, and shall at least wear the following items:

- Work clothes suitable for task
- Safety shoe
- Helmet

When the auto system is used, be sure to protect the operation personnel. The measures shall be taken to prevent the operation personnel from entering the range of manipulator.

The general precautions are listed below. Please take the appropriate measures to ensure the safety of operation personnel:

- The operation personnel running the manipulator system shall receive the training from the company and pass the relevant assessment.
- While the equipment is running, even if the manipulator seems to have stopped, the manipulator is possibly waiting for the start signal and is about to act. The manipulator shall be regarded as operating at this state. To ensure the safety of operation personnel, it is necessary to confirm that the manipulator is in the operating state via the audible and visual alarms such as the warning lamp
- Be sure to set the safety barrier and safety door around the system so that the operation personnel cannot enter the safety barrier without opening the safety door. The interlock switch, safety pin, etc. shall be set on the safety door so that when the operator opens the safety door, the manipulator will stop.
- Peripheral equipment shall be electrically grounded.
- The peripheral equipment shall be set outside the range of manipulator if possible.
- The range of manipulator shall be clearly marked with the lines on the floor to make the operator understand the range of manipulator including the mechanical arm and other tools.
- A proximity switch or photoelectric switch shall be installed on the floor so that when the operation personnel are about to enter the range of manipulator, the audible and visual alarms such as the buzzer are issued to stop the manipulator, thereby ensuring the safety of operation personnel.
- A lock shall be set to make sure that the manipulator power cannot be turned on except by the operation personnel responsible for the operation.
- Always disconnect the manipulator power when performing the individual commissioning of peripheral equipment.

### **Safety of operators**

Operators are not authorized to perform jobs within the safety barrier:

- Disconnect the power supply of manipulator control cabinet or press the emergency stop button when the manipulator is not operated.
- Operate the manipulator system outside the safety barrier.
- The guard fence and safety door shall be provided to prevent the unrelated personnel from entering the range of manipulator or to prevent operators from entering a hazardous location.
- Emergency stop button shall be set within the reach of operators.



Prompt

Manipulator controller is designed to be connected to an external emergency stop button. With this connection, the manipulator will stop when the external emergency stop button is pressed.

### Safety of teachers

In some cases, it is necessary to enter the scope of operation of the operator when carrying out the operation of the operator, especially at this time, the safety should be paid attention to:

- If you do not need to enter the operation maneuvering range, be sure to operate outside the operating maneuvering range.
- Before proceeding with the teaching, verify that the manipulator or peripheral equipment is in a safe state.
- If it is inevitable to enter the range of manipulator to conduct the teaching, first confirm the positions and states of safety devices (such as the emergency stop button, emergency automatic stop switching of teach pendant, etc.).
- Teachers shall pay special attention to make other people away from the range of manipulator
- Before starting the manipulator, first confirm that there is no people and no abnormality in the range of manipulator.
- After the teaching is over, be sure to perform the test run following the steps below:
  - Step1. At low speed, execute at least one cycle intermittently to confirm no abnormality.
  - Step2. At low speed, execute at least one cycle continuously to confirm no abnormality
  - Step3. At intermediate speed, execute at least one cycle continuously to confirm no abnormality
  - Step4. At operating speed, execute at least one cycle continuously to confirm no abnormality
  - Step5. Execute the program in automatic operation mode.
- The teacher must evacuate outside the safety fence when the operator operates automatically.

### Safety of repSOT engineer

To ensure the safety of repSOT engineer, full attention shall be paid to the following items:

- Never enter the range of manipulator while the manipulator is running.
- Perform the repSOT operation while the controller is powered off if possible. Main circuit breaker shall be locked to prevent other personnel from turning on the power.
- If it is Inevitable to enter the range of manipulator when it is powered on, you shall first press the emergency stop button of control cabinet or teach pendant. In addition, the operators shall hang the "RepSOTing" sign to remind other people not to operate the manipulator.
- Before performing a repSOT, verify that the manipulator or peripheral equipment is in a safe status.
- Do not perform the automatic operation when there is someone in the range of manipulator.
- When working near the walls and appliances, or when several operators are close to each other, be careful not to block the escape routes of other operators.
- When the manipulator is equipped with a tool, and there are movable devices such as conveyor belts in addition to the manipulator, pay attention to the operation of these devices.
- A person who is familiar with the manipulator system and is able to detect the danger shall be assigned next to the operating panel and operating box so that he can press the emergency stop button at any time.
- When replacing or reassembling the parts, be sure to prevent the foreign matters from sticking or entering.
- In case of the repSOT inside the controller, If the unit, printed circuit board, etc. may be contacted, be sure to disconnect the power supply of main circuit breaker of controller to prevent electric shock.
- Be sure to replace with the parts designated by us.
- When the manipulator system is restarted after the repSOT operation, it shall be confirmed in advance that there is no people in the range of manipulator, and the manipulator and peripheral equipment are in a normal status.

### **Safety of peripheral equipment**

Precautions in terms of procedures:

- The detection devices such as the limit switch shall be used to detect the dangerous status, and the manipulator shall be stopped as needed according to the signals of detection device.
- In case of abnormalities of other manipulators or peripheral equipment, the measures shall be taken, such as stopping the manipulator, even if there is no abnormality in the manipulator.
- For the system of which the manipulator is operating synchronously with the peripheral equipment, special care shall be taken to avoid the interference with each other.

- The manipulator may be interlocked with peripheral equipment and the manipulator may be stopped if required so as to control the status of all devices in the system from the manipulator.

Mechanical precautions:

- Manipulator system shall be kept clean and the use environments shall be free of grease, water, dust, etc.
- Do not use the cutting fluids and cleaning agents of unknown nature.
- Limit switches and mechanical brakes shall be used to limit the operation of manipulator to avoid the collisions between the manipulator and peripheral equipment.
- User cables and hoses shall not be added to the manipulator.
- When installing the cable outside the manipulator, do not interfere with the movement of machine.
- For the models of which the cable is exposed, do not conduct the modification that will interfere with the exposed part of cable.
- When installing the external device on the manipulator, be sure not to interfere with other parts of manipulator.
- For the manipulator in action, the frequent power-off operation via the emergency stop button may lead to the fault of manipulator.

### **Mechanical safety of manipulator**

Precautions for operation:

When the manipulator is operated in slow feed mode, the operators shall be highly vigilant regardless of the circumstances and quickly respond to various problems.

Precautions in terms of procedures:

If the ranges of multiple manipulators overlap, care shall be taken to avoid the interference between manipulators.

Be sure to specify an operation origin for the manipulator program and create a program that starts and ends at the origin, so that it is clear from the outside whether the manipulator operation has ended.

Mechanism precautions:

The working environments of manipulator shall be kept clean and free of grease, water, dust, etc.

### **Safety of end effector**

When controlling various types of transmissions (pneumatic, hydraulic, and electrical), after issuing the control command, be sure to fully consider the time difference from the issuance to the actual action and conduct the control with certain room of extension and retraction.

A detection unit shall be set on the end effector to monitor the status of end effector and control the action of manipulator.

# Contents

---

Foreword.....	I
General safety description .....	V
Safety protection measures before use .....	XI
Contents .....	i
<b>1 Product specification .....</b>	<b>1</b>
1.1 General functions and intended applications .....	1
1.2 Environmental conditions and working and storage limitations .....	1
1.2.1 <i>Environmental requirements</i> .....	1
1.2.2 <i>Environmental conditions for long-term storage</i> .....	1
1.2.3 <i>Precautions for storage</i> .....	2
1.3 Basic specifications .....	2
<b>2 Definition .....</b>	<b>5</b>
2.1 Introduction to industrial robots .....	5
2.2 Basic configuration of manipulator .....	5
2.3 Product label and meaning .....	6
2.3.4 <i>Manipulator nameplate</i> .....	7
2.3.5 <i>Manipulator transportation posture label</i> .....	7
2.3.6 <i>No approaching label</i> .....	8
2.3.7 <i>Direction identification of each axis of the manipulator</i> .....	8
<b>3 Preparation before use .....</b>	<b>11</b>
3.1 Product unpacking .....	11
3.1.1 <i>Unpacking method</i> .....	11
3.1.2 <i>Safe disposal of packaging materials</i> .....	12
3.1.3 <i>Disposal of waste materials</i> .....	12
3.2 Transportation and handling .....	12
3.2.1 <i>Handling posture</i> .....	13
3.2.2 <i>Transport dimensions</i> .....	14
3.2.3 <i>Transportation method</i> .....	15
3.3 Preparation before installation .....	16
3.3.1 <i>Check item</i> .....	16
3.3.2 <i>Installation tools and required connectors</i> .....	16
3.4 Installation and assembly .....	17
3.4.1 <i>Technical specifications</i> .....	17
3.4.2 <i>Fixed way</i> .....	17
<b>4 Electrical interface .....</b>	<b>23</b>
4.1 Manipulator electrical interface type .....	23
4.2 The definition of heavy load and aviation plug interface .....	24
<b>5 Adaptation and connection of products and accessories .....</b>	<b>29</b>



5.1	Connection of manipulator and accessories .....	29
5.2	Connection of manipulator and control cabinet .....	30
5.3	Power connection .....	31
<b>6</b>	<b>Job description .....</b>	<b>33</b>
6.1	Safe operation .....	33
6.1.1	<i>Dimensions and working range of each axis</i> .....	33
6.1.2	<i>Mechanical limit</i> .....	34
6.1.3	<i>Stop mode</i> .....	34
6.2	Calibration .....	35
6.2.1	<i>When is calibration required</i> .....	35
6.2.2	<i>Calibration position of each axis</i> .....	35
6.2.1	<i>Movement direction of each axis</i> .....	37
6.2.2	<i>Speed of each axis</i> .....	38
6.3	Output flange size .....	38
6.4	Load and installation method .....	39
<b>7</b>	<b>General Rules for Maintenance .....</b>	<b>45</b>
<b>8</b>	<b>Preventive maintenance .....</b>	<b>47</b>
8.1	Daily maintenance .....	47
8.2	First maintenance .....	47
8.3	Regular maintenance .....	48
<b>9</b>	<b>Project maintenance process .....</b>	<b>51</b>
9.1	Cleaning the manipulator .....	51
9.2	Check and repSOT cables .....	51
9.3	Replacing the battery .....	53
9.4	Replace timing belt .....	54
<b>10</b>	<b>Fault finding, diagnosis and repSOT .....</b>	<b>57</b>
	<b>Appendix A type manipulator regular maintenance table .....</b>	<b>63</b>
	<b>Appendix B Table of screw strength and tightening torque (Nm) .....</b>	<b>67</b>

# 1 Product specification

## 1.1 General functions and intended applications

Industrial robot systems are used to move tools and devices, or process and transport workpieces or products. It is allowed to be used only in accordance with the specified climatic and environmental conditions. For specific storage conditions and working environment requirements, please refer to Chapter 1.2.

All non-compliant use is illegal and prohibited. These non-compliant uses include:

- Use in environments where there is a danger of explosion.
- Use outside the allowed motion range.
- Transporting people or animals.
- Used as a climbing aid.

 Caution	Changing the structure of the robot, such as drilling holes, can cause component damage. This is regarded as improper use and will result in loss of warranty and claim eligibility.
--	--

## 1.2 Environmental conditions and working and storage limitations

### 1.2.1 Environmental requirements

See Table 1- 1 for the operating environment requirements of manipulator.

Table 1- 1 Environmental requirements for equipment manipulator

Temperature	Lowest temperature	0°C
	Maximum temperature	40°C
Humidity	The operating environment requirements of the manipulator do not exceed the humidity level not higher than 95% as specified in the document "IEC 60721-3-3-2002 Classification of environmental conditions".	
Altitude	The altitude of the normal operating environment of the manipulator should not exceed 1000 meters. In the height range of 1000 meters-4000 meters, the manipulator should be reduced in rated power to use	
Shock resistance	The robot manipulator should be used in an environment without vibration as much as possible. The limit frequency of environmental vibration is 22Hz, and the amplitude does not exceed 0.15mm.	
Special environmental requirements	The manipulator is prohibited to use in flammable, explosive and corrosive environment.	

### 1.2.2 Environmental conditions for long-term storage

The manipulator should be placed in a cool place protected from direct sunlight and waterproof during long-term storage. The specific environmental requirements are shown in Table 1- 2 below.

Table 1- 2 Manipulator long-term storage environmental conditions

Parameter	Value
Minimum ambient temperature	-25°C
Maximum ambient temperature	55°C
Maximum ambient temperature (storage time less than 24h)	70°C
Maximum ambient humidity	Less than 95% at constant temperature, no condensation
Maximum vibration conditions	Frequency 22Hz, amplitude 0.15mm

### 1.2.3 Precautions for storage

In addition to the content of Chapter 1.2.1 of this manual, the long-term storage of the manipulator should also pay attention to the following items:

- Before long-term storage of the manipulator, the posture should be in the transport posture, placed on a horizontal surface and fixed, see Chapter 3.3 of this manual for details.
- When the manipulator is not used for a long time, all power supply should be cut off.
- Use an outer protective cover such as paper or wooden packaging box to protect the manipulator from external light to avoid long-term exposure to the manipulator or exposure to water, oil, corrosive liquids, etc.
- The surface of the manipulator should be cleaned regularly, such as dust removal and decontamination. The specific cleaning cycle depends on the storage environment of the manipulator.
- When the storage period ends and the manipulator is put back into use, the manipulator must be inspected in accordance with Chapter 3.3.1 of this manual.

## 1.3 Basic specifications

The basic specifications of robot are shown in Table 1- 3.

Table 1- 3 Basic specifications of robot

Coordinate form	Six-degree-of-freedom articulated robot	
Number of control axes	6 axis(J1,J2,J3,J4,J5,J6)	
Installation method	Ground installation, wall installation, upside-down installation*	
Fixed method	Ground fixed	Can only be used for ground installation
	Bracket fixed	Can be used in 3 installation methods
Action range (upper/lower limit)	J1**	-170°~170°
	J2	-100°~135°
	J3	-120°~156°
	J4	-200°~200°
	J5	-135°~135°
	J6	-360°~360°
Maximum operating speed	J1	380°/s

	J2	320°/s
	J3	390°/s
	J4	490°/s
	J5	565°/s
	J6	815°/s
Handling weight	Wrist + elbow	7kg
Drive method	Use AC servo motor for electrical servo drive	
Repeatability	±0.02mm	
Robot quality	53kg	
Noise	70dB	
IP protection level	IP67	
Installation conditions	Ambient temperature: 0~45°C Humidity: within 95% at constant temperature, no condensation Allowable height: below 1000m above sea level There should be no corrosive, flammable, explosive gases	

Note: The "\*" installation method adopts wall or upside-down installation. Please consult our company for the range of motion and speed limit.

"\*\*" stipulates that if the mechanical limit of the J1 axis is removed, the movement range of the J1 axis can reach -180° ~ 180°

## 2 Definition

---

### 2.1 Introduction to industrial robots

The industrial robot system is mainly composed of three basic parts: industrial robot manipulator, control cabinet and teach pendant:

- Manipulator refers to the mechanism used to grab or move objects (tools or workpieces) in the robot system, also known as the robot body. This manipulator is a six-degree-of-freedom tandem industrial robot, including three swing axes and three rotation axes.
- Control cabinet is installed with the electrical equipment needed to control the robot, and provides a connection interface with the robot manipulator and other external equipment.
- Teach pendant is connected to the main control system of the control cabinet, and is used to control the manual/automatic operation of the robot, record the running track, display playback or record the teaching point and program according to the teaching point.

The structure of industrial robot system is shown in Figure 2-1.

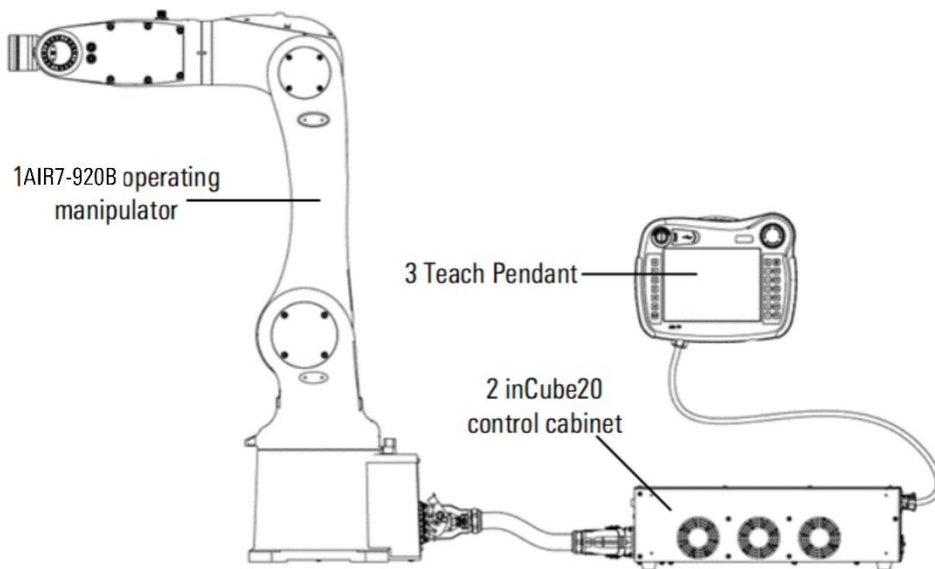

Figure 2-1 The composition of industrial robot system

### 2.2 Basic configuration of manipulator

The names of type manipulator and each part of it are shown in Figure 2-2.

For the basic specifications of the manipulator, please refer to Chapter 1.3 of this manual. For the dimensions and working range of each axis, please refer to Chapter 6.1.1 of this manual.

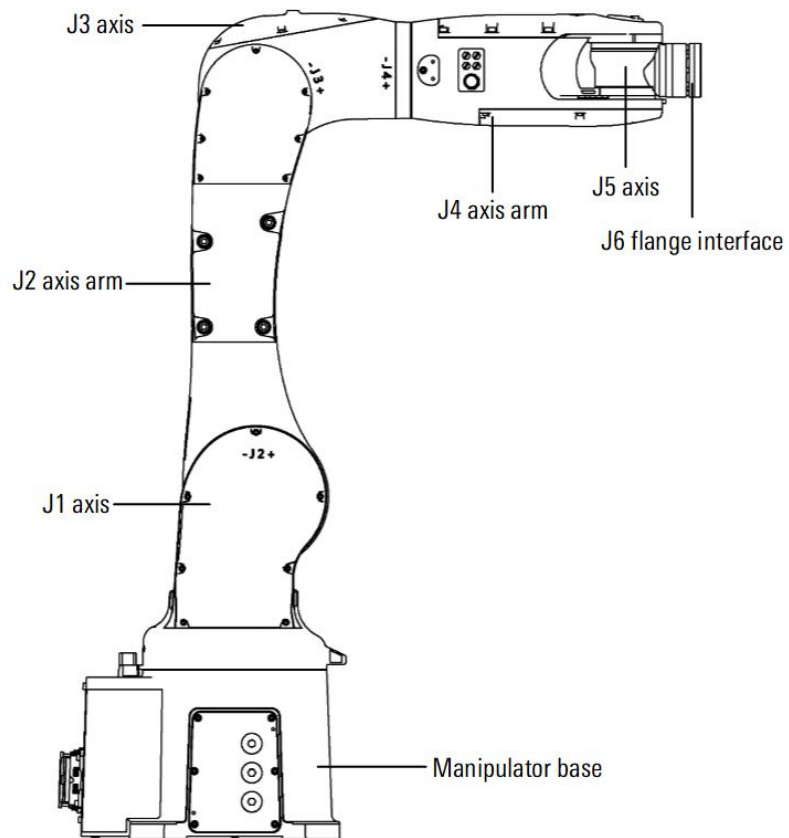

Figure 2-2 manipulator body and its parts

## 2.3 Product label and meaning

Figure 2-3 shows the schematic diagram of the label position of the manipulator.

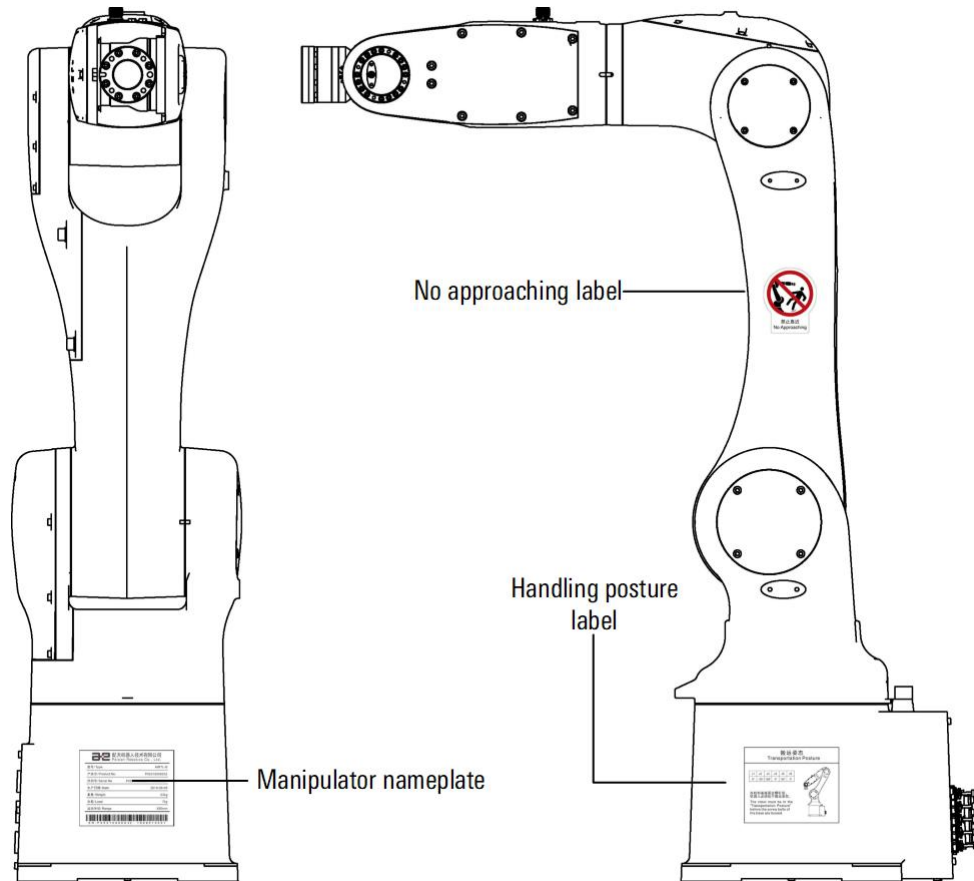

Figure 2-3 Label location diagram

### 2.3.1 Manipulator nameplate

The nameplate of the manipulator is attached to the base. The nameplate contains the corresponding model, product number, weight, serial number, production date and other information of the corresponding product (refer to Figure 2-3). The nameplate information is subject to the actual factory shipment. Refer to Figure 2-4 for the specific location of the nameplate.

型号/Type	7L-920
产品号/Product No.	P05310000032
序列号/Serial No.	P05310000032-1908090001
生产日期/Date	2019-08-09
重量/Weight	53kg
负载/Load	7kg
运动半径/Range	920mm
 SN: P05310000032-1809010001	

Figure 2-4 Schematic diagram of nameplate of manipulator

### 2.3.2 Manipulator transportation posture label

manipulator transportation posture label is shown in Figure 2-5. Refer to Figure 2-3 for the specific location of the label.

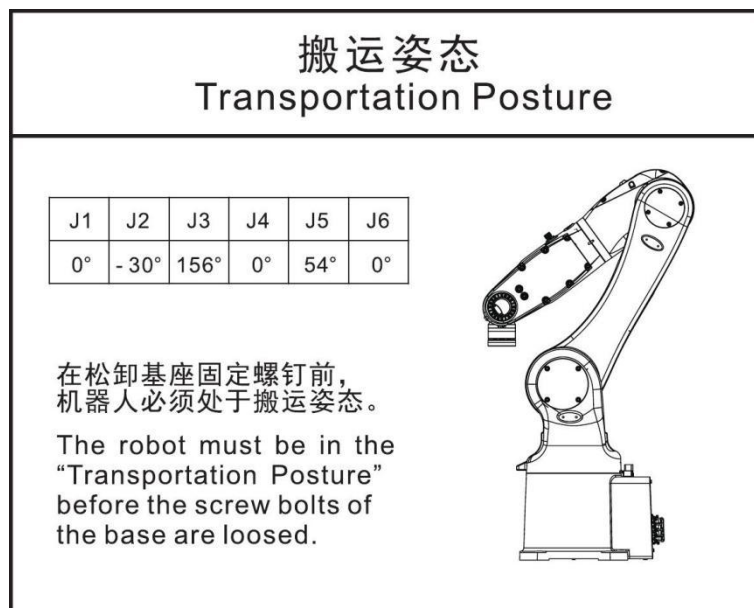

Figure 2-5 manipulator transportation posture label

### 2.3.3 No approaching label

On the back of the manipulator's arm, there is a "No Approaching Label" (as shown in Figure 2-6). Refer to Figure 2-3 for the specific location of the label.



Figure 2-6 Do not approach the label

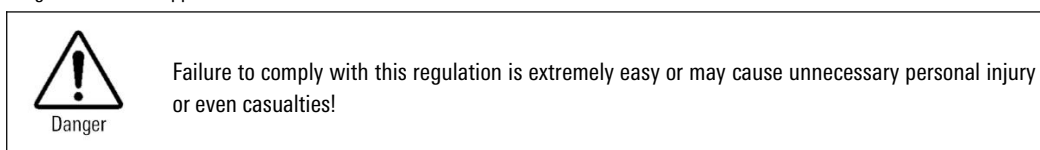

### 2.3.4 Direction identification of each axis of the manipulator



There are signs of positive and negative movement directions at the connecting parts where the manipulator 1 to 6 axes rotate or swing, as shown in Figure 2-7 below, which shows the movement direction of each axis. The number "J1" in the label represents axis 1 (other axes are represented by corresponding numbers), "+" represents the positive direction of motion, and "-" represents the negative direction of motion.

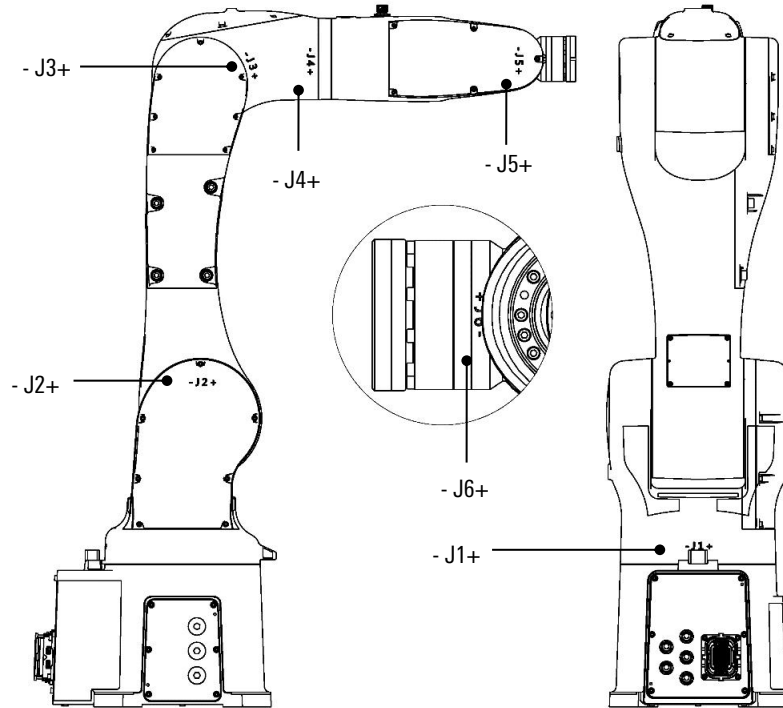

Figure 2-7 Direction identification of each axis on the manipulator



## 3 Preparation before use

---

### 3.1 Product unpacking

#### 3.1.1 Unpacking method

As shown in Figure 3-1, the packaging box of the manipulator is composed of a box body and a bottom support.

**Operation process of unpacking:**

- Step1. Disassemble the packaging bag of the wrapping manipulator and take out the built-in calcium chloride desiccant.
- Step2. Use an Allen wrench to unscrew the four M10×35 hexagon socket head screws, washers and M10 hexagon nuts that connect the manipulator and the bottom bracket to separate the manipulator from the bottom bracket. If the screws are loose, please avoid tilting the manipulator and prevent the manipulator from tipping over.

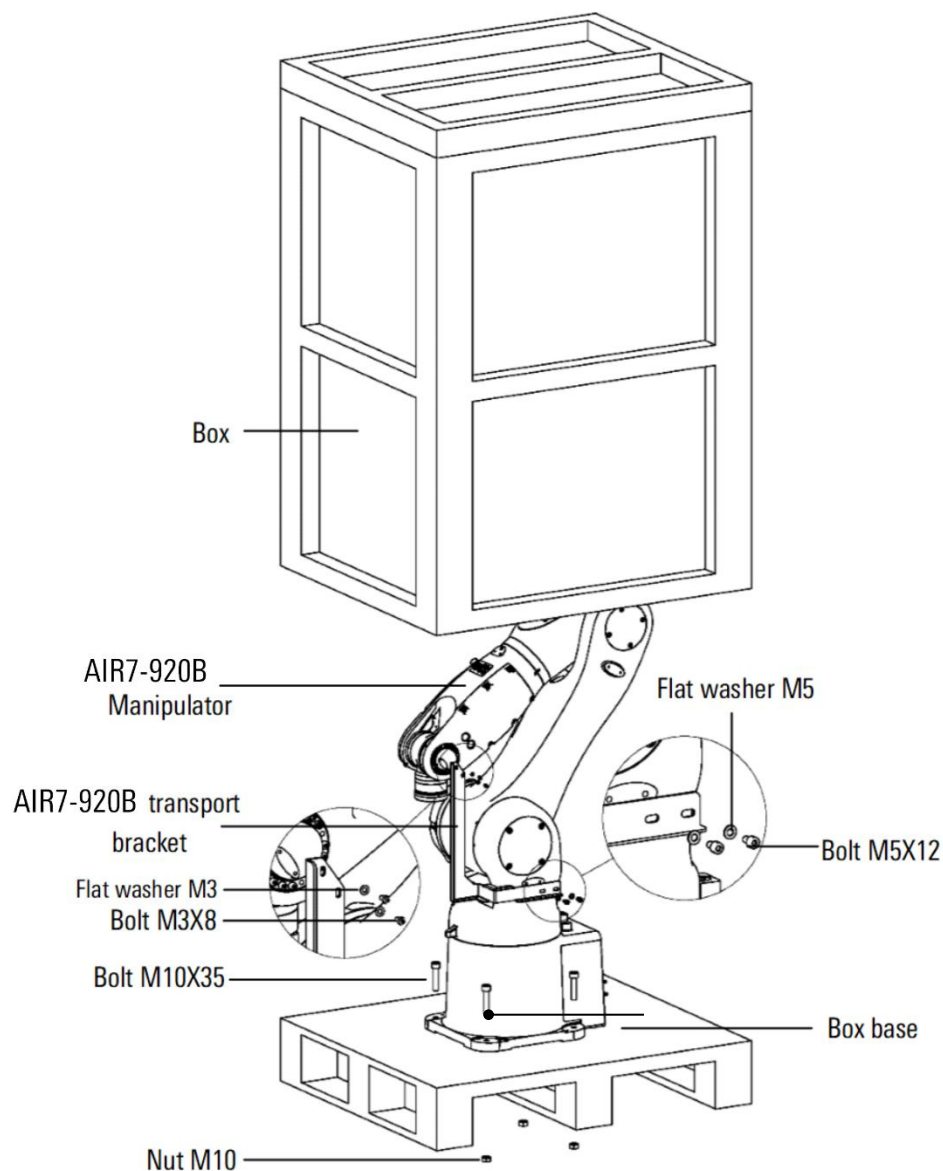

Figure 3-1 Manipulator packaging diagram

### 3.1.2 Safe disposal of packaging materials

- In order to facilitate repacking, please properly save the carton, the bottom bracket and all the screws and nuts and other parts used in connection. Please keep the above materials in a dry and clean indoor place to prevent the materials from moisture, pressure, heat or close to fire source.
- If you don't need to keep the above materials, please handle them properly according to the relevant disposal methods of industrial waste.
- The packaging bag and calcium chloride desiccant cannot be used again after unpacking, please handle it properly according to the relevant disposal methods of industrial waste.

### 3.1.3 Disposal of waste materials

Industrial robot system waste disposal must be carried out in accordance with the laws, regulations and standards of each country.

## 3.2 Transportation and handling

 Warning

When handling the manipulator, it is necessary to install the supporting transport bracket. If the manipulator is used incorrectly, the manipulator may be damaged. The posture of the manipulator during transportation is subject to the description in Chapter 3.2.1 of this manual. The matters needing attention during the handling of the manipulator are shown in Figure 3-2.

 **注意**  
**CAUTION**



不要向旁侧拉引吊环螺钉  
Do not pull eyebolt sideways



不要以叉车等的卡爪给运送构件施加冲撞力  
Do not have impact on this part



不要在运送构件上挂上链条  
Do not chain, pry, or strap on this part

Figure 3-2 Precautions during the handling of the manipulator

### 3.2.1 Handling posture

Refer to Table 3- 1 for the angle value of each axis when manipulator is transported.

Table 3- 1 Angle value of each axis during robot handling

A1	A2	A3	A4	A5	A6
0°	-30°	156°	0°	54°	0°

Figure 3-3 shows the pose diagram of the manipulator when it is being transported.

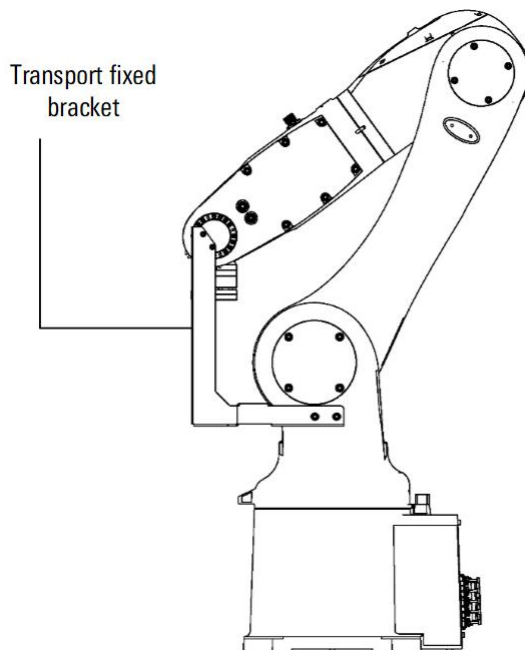



Figure 3-3 manipulator handling pose diagram



Warning

- The manipulator must strictly follow the posture in Table 3-1 when carrying it, otherwise it may tip over due to unstable center of gravity.
- When the manipulator is transported over a long distance or with strong vibration, it is necessary to install the transport and fixing bracket in Figure 33 to prevent excessive transport vibration from causing mechanical damage. The transportation and fixing bracket is provided in the factory packaging, please keep it in a safe place for the second transportation.

### 3.2.2 Transport dimensions

Please refer to Figure 3-4 for the dimensions of the three views of the manipulator during transportation.

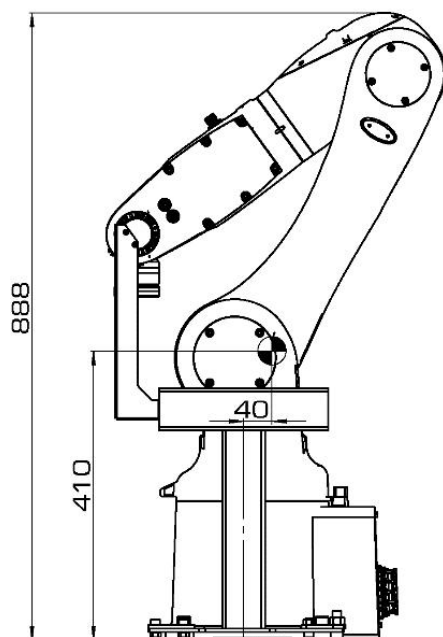

(a) right view

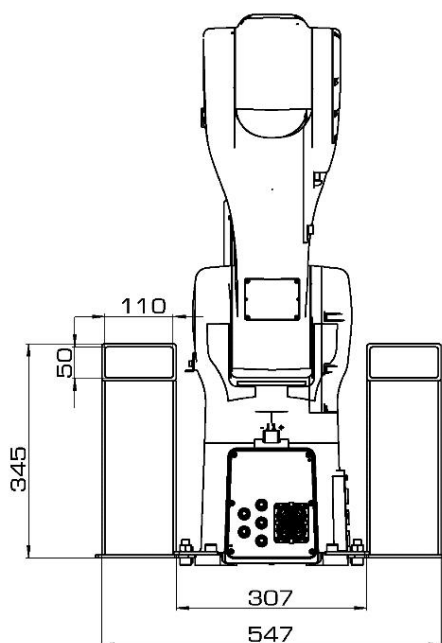

(b) Rear view

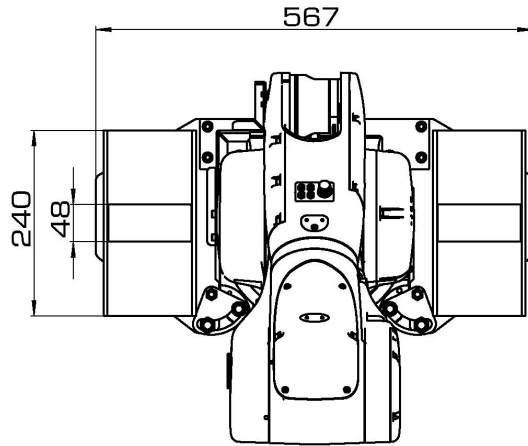

(c) Top view

Figure 3-4 manipulator size during transport

 Warning	The actual size may be slightly larger than the size in Figure 3-4, so be careful.
--	--

### 3.2.3 Transportation method

#### Handing with forklift

Handling with forklift is as shown in Figure 3-5. Forklift shall meet the requirement for the weight (53Kg) of manipulator. The total weight of manipulator and handling device is about 70kg.

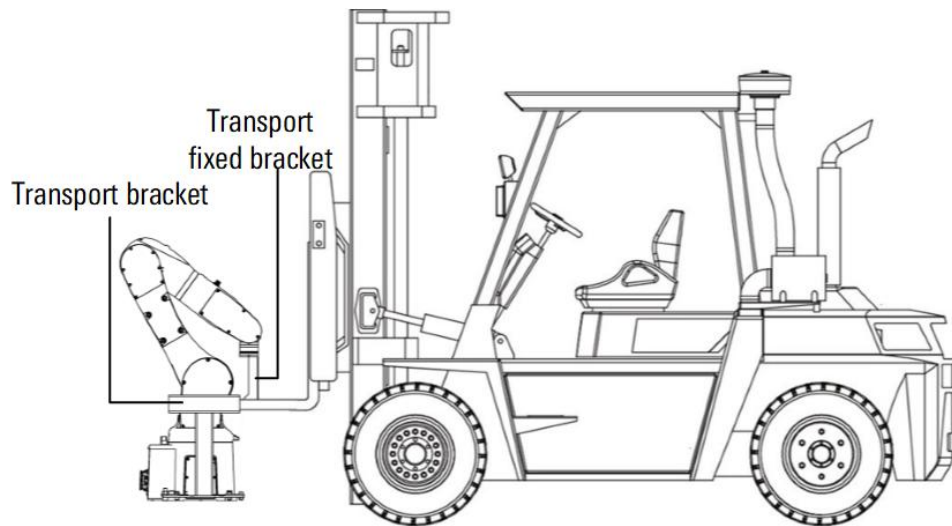



Figure 3-5 Schematic diagram of forklift handling

 Warning	When the manipulator is transported by a forklift, a supporting transport bracket (optional accessory) must be installed. If the manipulator is incorrectly transported, the manipulator may be damaged. The posture of the manipulator during transport shall be subject to the description in Chapter 3.2.1 of this manual.
--	---

## Handling with swinging ring

Handling with swinging ring is as shown in Figure 3-6 lifting device shall meet the requirement for the weight (53kg) of manipulator. The total weight of manipulator and handling device is about 55kg.

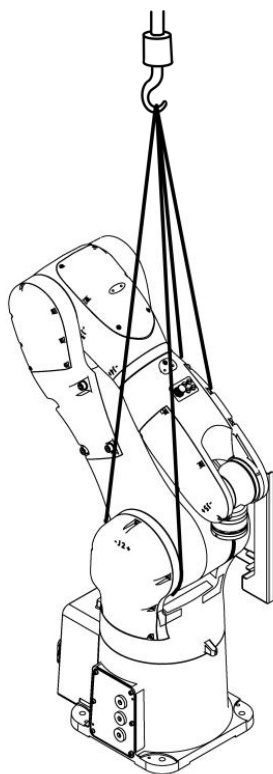

Figure 3-6 Schematic diagram of lifting ring handling



Caution

- When manipulator is handled with swinging ring, insert a soft object between the sling and manipulator to avoid the scratching on the manipulator body by sling.
- Manipulator may turn over when transported with swinging ring. During the handling, please take special care to keep the manipulator steady.
- Do not pull the swinging ring to the side to avoid the damage to the manipulator and the unpredictable failure.

## 3.3 Preparation before installation

### 3.3.1 Check item

Following requirements shall be strictly adhered to before installation:

- Ensure that the installers pass the relevant training of company and perform the installation according to the international and local laws and regulations.
- After the unpacking, make sure that the product is not bumped or damaged
- Make sure that the carrier bracket, swinging ring screws, etc. are installed to the manipulator as required.
- Make sure the installation environments are as required by Chapter 1.2.1.
- Make sure that the installation site can withstand the pressure or pull from the manipulator and its load. (At the fixed position of the base of the manipulator, it can bear the equivalent load of not less than 2kN and the moment of 600Nm in all directions)

### 3.3.2 Installation tools and required connectors



The following tools may be required to install the manipulator (more tools may be required, depending on the specific installation method):

- An allen wrench
- Adjustable wrench
- Torque wrenches of different specifications, etc.

The connection parts that may be required for the installation of the manipulator are as follows (more connection parts may be required, depending on the specific installation):

- Several M10 cylindrical head hexagon socket screws with appropriate length and strength grade of 12.9 or other size specifications.
- Several chemical bolts with appropriate length and strength grade not less than 4.8.
- Several spring pads of  $\Phi 10$  or other specifications.
- There are several cylindrical pins with a diameter of 6mm. For details, see Chapter 3.4.2 of this manual.

## 3.4 Installation and assembly

### 3.4.1 Technical specifications

When installing the manipulator, the strength of the foundation installation surface should be fully considered. The inclination of the manipulator installation ground should be less than 5°.

The base size of the manipulator is shown in Figure 3-7. Among them, M12 threaded holes can be used as through holes for installing M10 screws, and M5 threaded holes can be used for equipment grounding cable connection; if high-precision positioning is required,  $\Phi 6H7$  pin holes can be used as positioning holes.

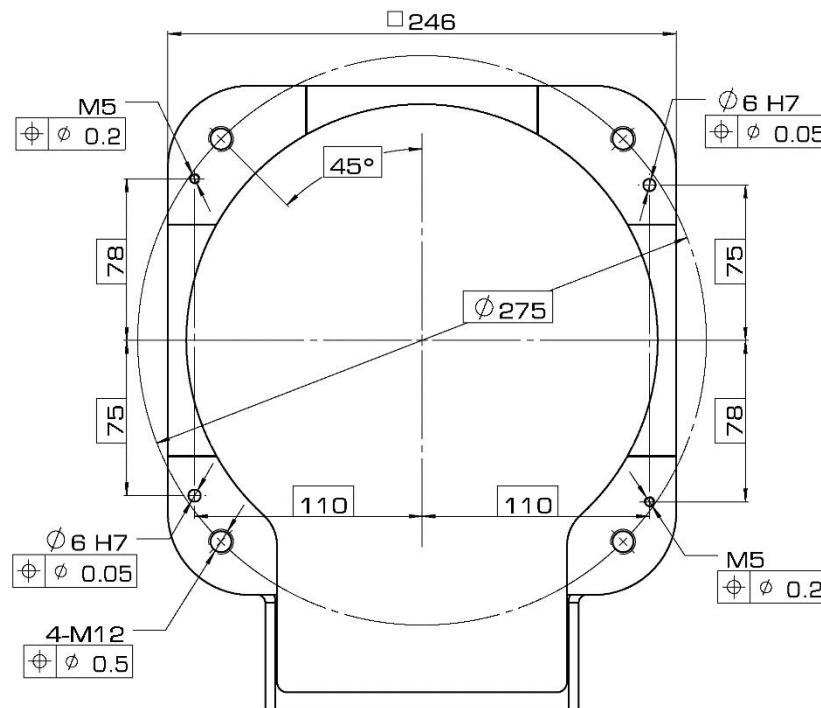

Figure 3-7 type manipulator base interface size

### 3.4.2 Fixed way

The manipulator provides two fixing methods: "ground fixing" and "bracket fixing".



 Prompt	<ul style="list-style-type: none"> <li>■ The specific fixing method should be appropriately selected according to the environment used by the user.</li> <li>■ The strength of chemical bolts is affected by the strength of concrete. For the construction of chemical bolts, please refer to the design guidelines of each manufacturer and fully consider the safety before use.</li> </ul>
---	--

Table 3- 2 shows the names and specifications of the parts and components required to fix the manipulator.

Table 3- 2 Parts required for manipulator fixing

Parts name	Remarks	Ground fixed	Bracket fixed
Fixing screws	M10x35 (12.9 level) 4	○	○
Chemical bolt	M20 (not lower than 4.8 level) 4	○	
Robot fixed plate	20mm thickness, 1 piece	○	
Mounting brackets	Mounting plate thickness 20mm		○

 Prompt	<ul style="list-style-type: none"> <li>■ There must be no insulating material between the robot fixed plate and installation bracket, the manipulator, and the concrete.</li> <li>■ The representatives with "○" mark need this part.</li> <li>■ The bracket must be firmly installed on the ground, and the strength should not be less than the fixing strength of the robot fixing plate and the ground in the "ground fixing".</li> </ul>
--	---

## Ground fixed

Fixing steps:

- Step1. According to the recommended size shown in Figure 38, arrange M20 chemical bolts (strength grade not less than 4.8) on the concrete foundation. Please strictly follow the instructions for the selected chemical bolts for installation;
- Step2. Place the robot fixing plate close to the installation plane. After placing it securely, fix it with four M20 hexagon nuts (strength grade not less than 4.8) and M20 flat washers;
- Step3. In the handling posture, transfer the manipulator to the top of the robot fixing plate, and adjust the direction of the manipulator to make the M12 threaded hole holes of the base align with the M10 threaded holes of the robot fixing plate;
- Step4. Check whether the base is tightly attached to the fixed plate without shaking. Use 4 M10x35 screws (strength grade 12.9) to fix the base of the manipulator to the fixed plate.

 Prompt	<p>The surface of the fixing plate should meet certain installation requirements, see Figure 3-8 for details.</p>
---	---

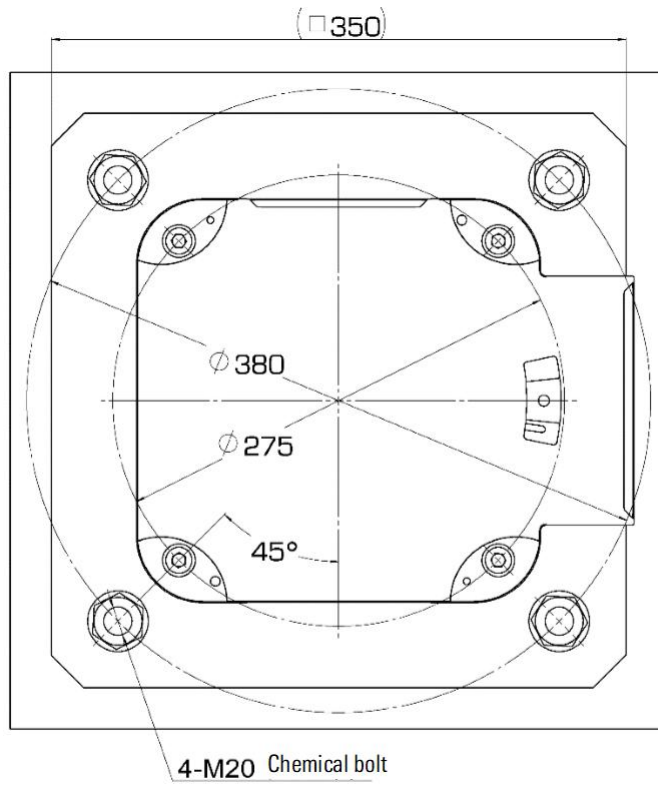

(a) Layout size

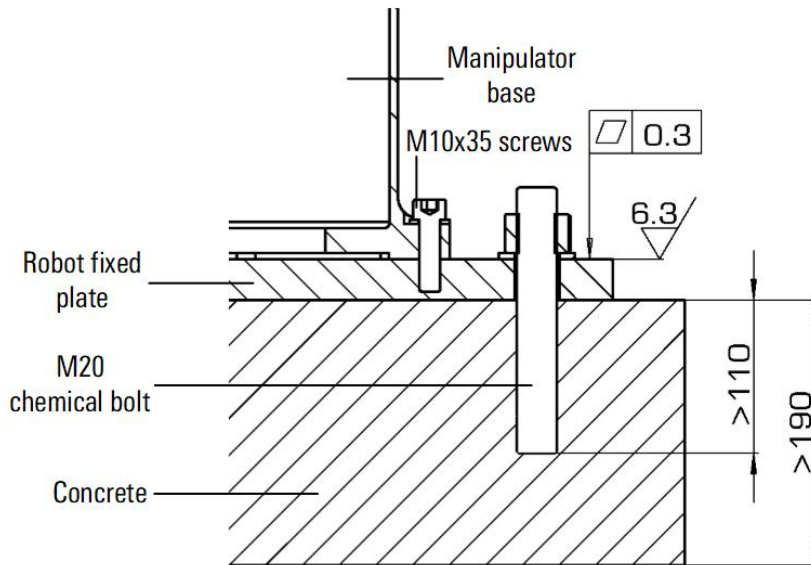

(b) Section view

Figure 3-8 Ground fixed diagram

### Bracket fixed

 Warning	<ul style="list-style-type: none"> <li>■ The length of the manipulator fixing screw M10 should not be shorter than 35mm. Too short length will cause accidents such as poor fixing.</li> <li>■ When installing the manipulator on the ceiling, it is necessary to increase the length of the manipulator fixing screw to 40mm, while ensuring that the thickness of the mounting plate is not less than 25mm.</li> </ul>
-------------	--

Fixing steps:

Step1. In the handling posture, transfer the manipulator to the top of the mounting bracket, and adjust the direction of the manipulator to make the M12 threaded holes of the base align with the M10 threaded holes of the mounting bracket;

Step2. Check whether the base is closely attached to the surface of the mounting bracket without shaking. Use four M10x35 screws (strength grade 12.9) to fix the base of the manipulator on the bracket.



Prompt

The mounting surface of the bracket should meet certain flatness requirements, see Figure 3-9 for details.

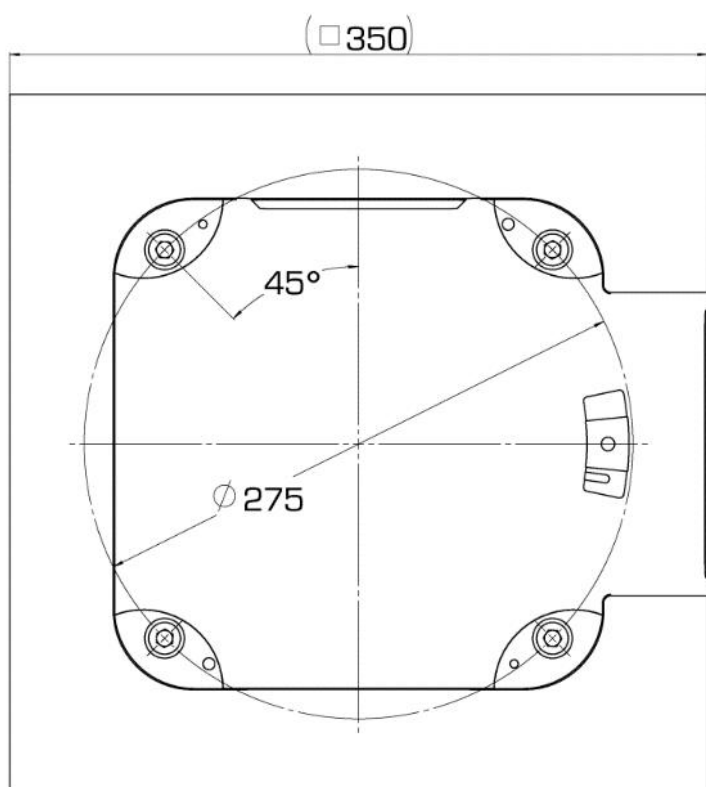

(a) Layout size

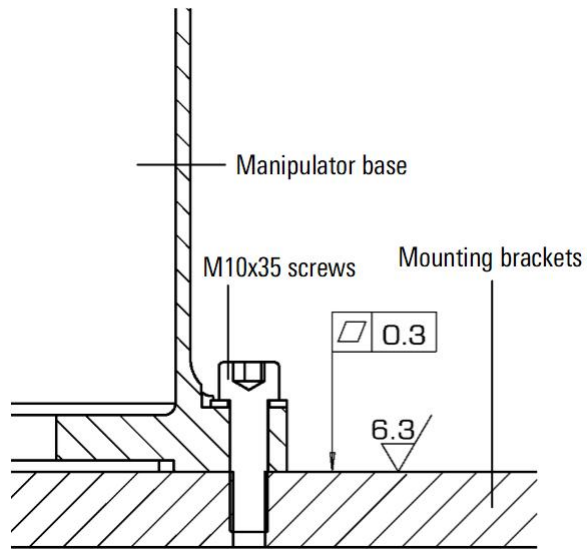

(b) Section view

Figure 3-9 Schematic diagram of bracket fixing

## 4 Electrical interface

### 4.1 Manipulator electrical interface type

There are heavy-duty connectors, SOT pipe joints and manual brake release buttons on the base of the manipulator. As shown in Figure 4-1(a), the right side is the heavy-duty connector, and the left side is five  $\phi 6$  quick tracheal joints. After removing the blind plug, you can directly insert the  $\phi 6$  trachea; as shown in Figure 4-1(b), Inside the ED plug are 3 manual brake release buttons.

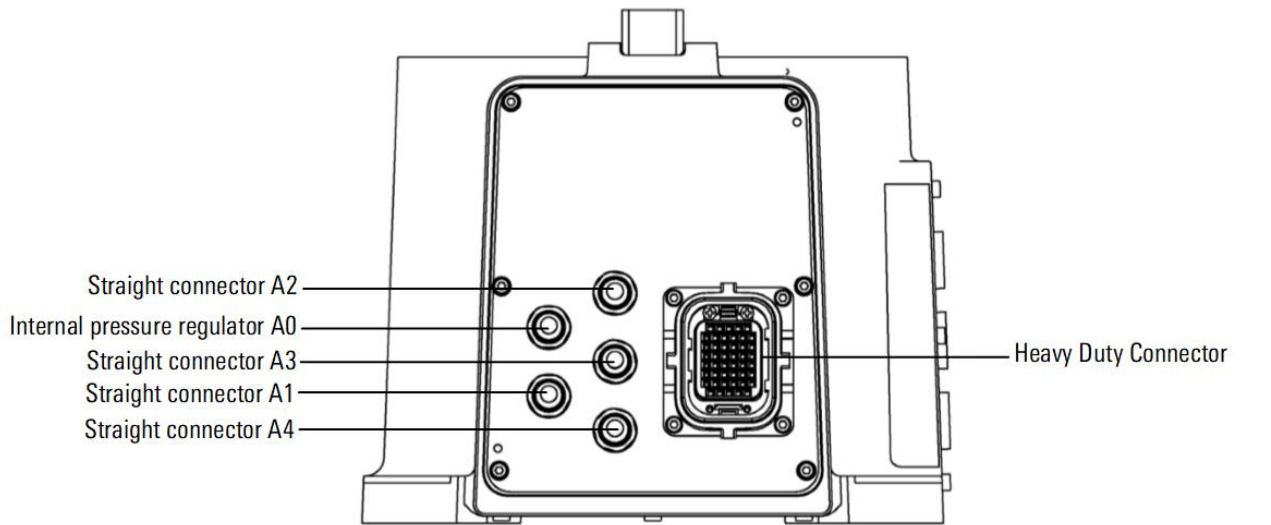

(a) Rear view

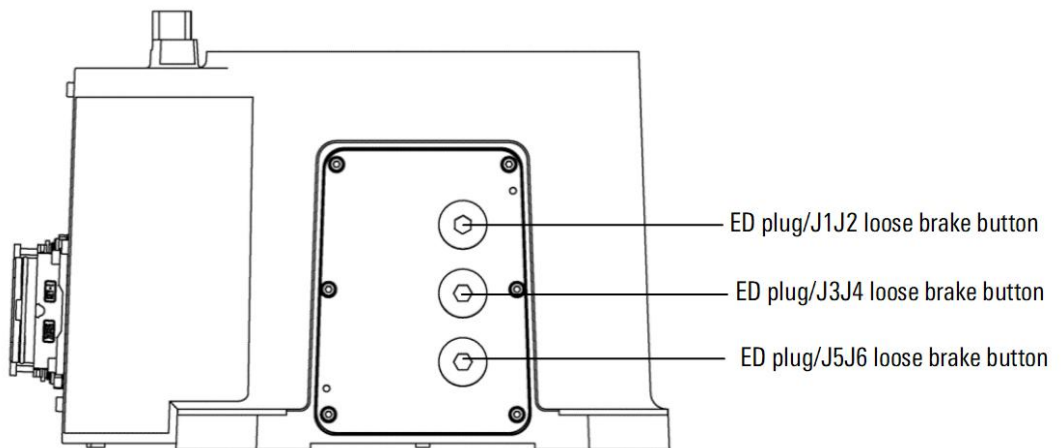

(b) Left view

Figure 4-1 manipulator base interface



Warning

When using the internal pressure regulating connector A0 to adjust the internal pressure of the manipulator, ensure that the internal and external pressure difference does not exceed 0.02MPa, and the internal pressure cannot be less than the external pressure, otherwise the sealing parts may be damaged.

There are aviation sockets (forearm IO interface) on the forearm of the manipulator and a gas path directly connected to the trachea joint of the base. The specific position is shown in Figure 4-2. The straight SOT path is blocked by the M5 screw plug. If you need to use it, you can unscrew the screw plug and connect the appropriate M5 SOT pipe joint to use.

Steps to manually release the brake:

Step1. To prevent the shaft from falling due to gravity when the brake is released, the manipulator needs to be fixed;

Step2. Use a wrench to remove the ED plug on the base, you can see the brake release button inside the base;

Step3. Connect the manipulator to the control cabinet, and connect the control cabinet to the power supply. For specific operations, see Chapter 5.2 and Chapter 5.3 of this manual;

Step4. Press and hold the brake release button to release the brakes of the 6 axes of the manipulator.



Caution

After performing the manual brake release operation, reinstall the ED plug on the base of the manipulator to prevent dust or liquid from entering the inside of the manipulator.

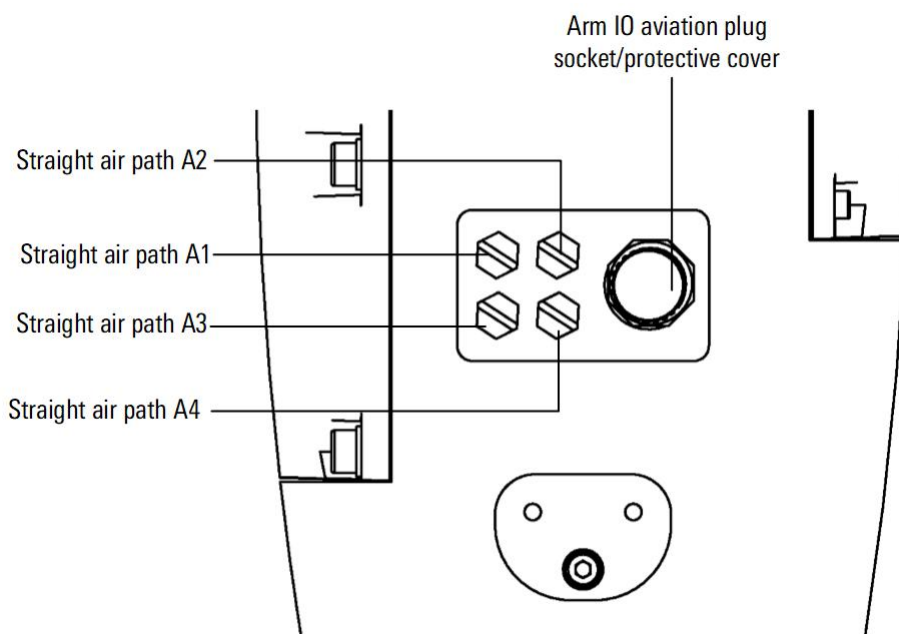



Figure 4-2 type manipulator upper arm interface



Warning

- The forearm IO interface (HRS/LF10WBRB-12P) of the forearm of the manipulator is equipped with a waterproof and dustproof cover. When the interface is not in use, please do not unscrew the cover to prevent dust or liquid from entering the manipulator.
- If you need to use the forearm IO interface, please select the corresponding option HRS/LF10WBPD-12S type aviation plug. For specific installation and usage methods, please refer to the detailed description of the corresponding model on the official website of Hirose [www.hirose.com](http://www.hirose.com).

## 4.2 The definition of heavy load and aviation plug interface

The definition of the heavy-duty interface (power line part) of the manipulator is shown in Table 4- 1.

Table 4- 1 Manipulator heavy load interface definition (power line part)

Signal name	Axis number	Pin number	Signal name	Axis number	Pin number
U1	1 axis	1f	U4	4 axis	5f
V1	1 axis	1g	V4	4 axis	5g
W1	1 axis	1h	W4	4 axis	5h
PE	1 axis	1d	PE	4 axis	4d
U2	2 axis	4f	U5	5 axis	3f
V2	2 axis	4g	V5	5 axis	3g
W2	2 axis	4h	W5	5 axis	3h
PE	2 axis	4d	PE	5 axis	1d
U3	3 axis	2f	U6	6 axis	5e
V3	3 axis	2g	V6	6 axis	6f
W3	3 axis	2h	W6	6 axis	6g
PE	3 axis	1d	PE	6 axis	4d

type manipulator heavy load interface definition (encoder line part) is shown in Table 4- 2.

Table 4- 2 Manipulator heavy load interface definition (encoder line part)

Signal name	Axis number	Pin number	Signal name	Axis number	Pin number
J1_PS+	1 axis	1a	J4_PS+	4 axis	4a
J1_PS-	1 axis	1b	J4_PS-	4 axis	4b
J2_PS+	2 axis	2a	J5_PS+	5 axis	5a
J2_PS-	2 axis	2b	J5_PS-	5 axis	5b
J3_PS+	3 axis	3a	J6_PS+	6 axis	6b
J3_PS-	3 axis	3b	J6_PS-	6 axis	6c
Encoder 0V	1-6 axis	1c	Encoder 24V	1-6 axis	2c

The definition of the heavy-duty interface (solenoid valve and arm IO part) of manipulator is shown in Table 4- 3.

Table 4- 3 Manipulator heavy-duty interface definition (brake and arm IO part)

Signal name	Axis number	Pin number
24V_BR+	1-6 axis	3e
24V_BR+2_0	1-6 axis	2e
GND_24VBR	1-6 axis	1e
E_NAME_BOARD_RS485_A	-	4c



Signal name	Axis number	Pin number
E_NAME_BOARD_RS485_B	-	3c

The heavy-duty interface of manipulator is shown in Figure 4-3.

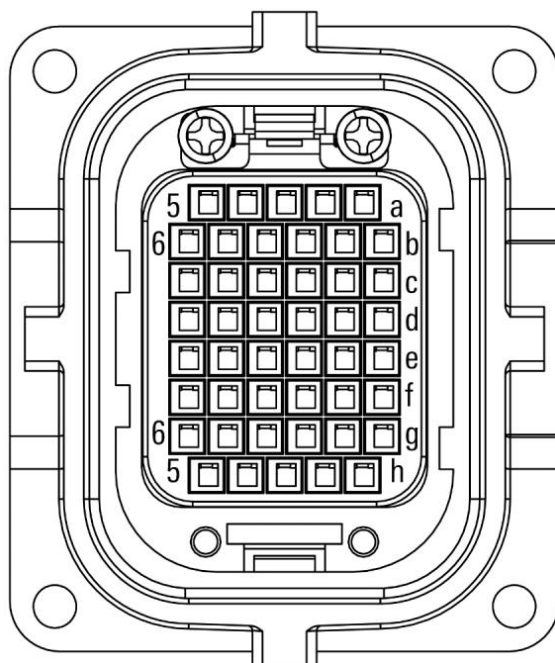

Figure 4-3 type manipulator heavy load interface



When the robot is connected to the control cabinet, either end of the heavy-duty cable can be plugged into the manipulator or the heavy-duty control cabinet.

The IO interface of the forearm of the manipulator is shown in Figure 4-4, and the related description of each interface is shown in Table 4- 4.

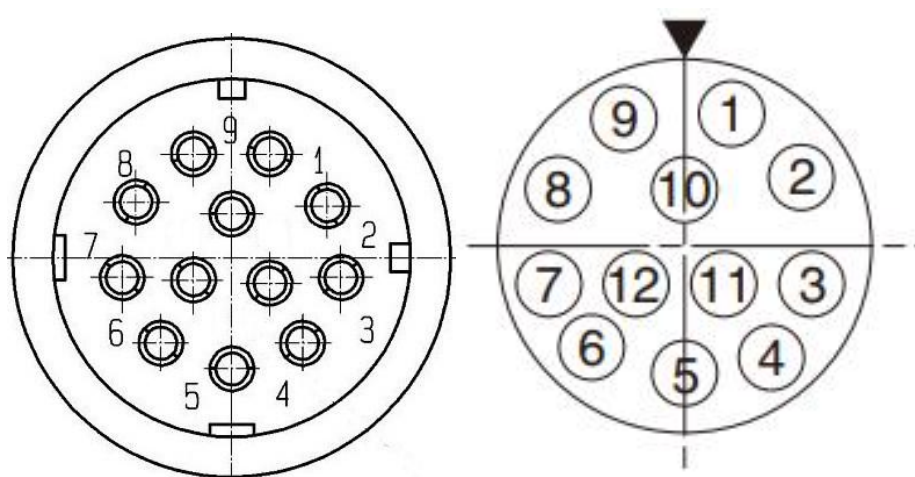

Figure 4-4 type manipulator arm IO interface

Table 4- 4 Forearm IO interface definition

Signal name	Connector number
24V	8
GND	9
DO0	6
DO1	7
DI0	1
DI1	2
DI2	3
DI3	4
DI4	5



## 5 Adaptation and connection of products and accessories

---

### 5.1 Connection of manipulator and accessories

The connection between the external auxiliary equipment of the manipulator and the manipulator is similar to the connection between the load and the manipulator, and it can be directly or indirectly connected to the manipulator via a flange. For details, see Chapter 6.4 of this manual.

Manipulator accessories and equipment mainly include mechanical grippers (refer to Figure 5-1), hydraulic and pneumatic suction cups (refer to Figure 5-2), welding torch welding machine (refer to Figure 5-3), infrared recognition equipment, visual recognition equipment, cutting machines, and other dedicated Equipment etc.

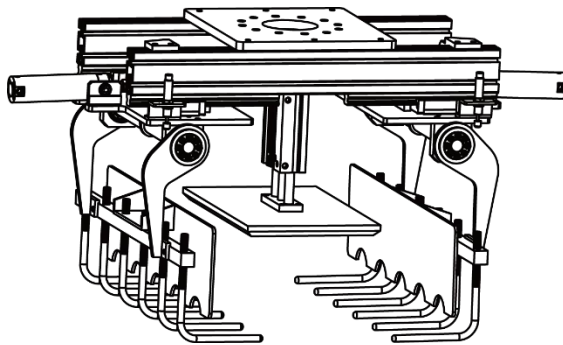

Figure 5-1 Grip for industrial robot

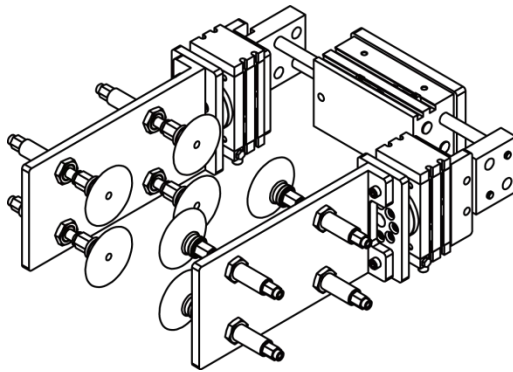

Figure 5-2 Suction cups for industrial robots

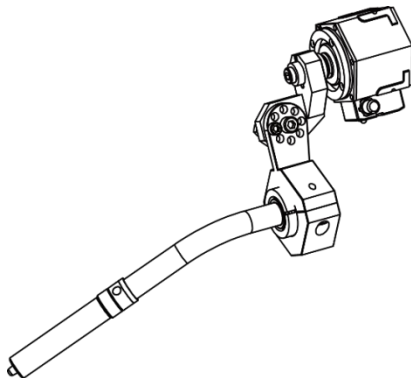

Figure 5-3 Arc welding torch for industrial robot

## 5.2 Connection of manipulator and control cabinet

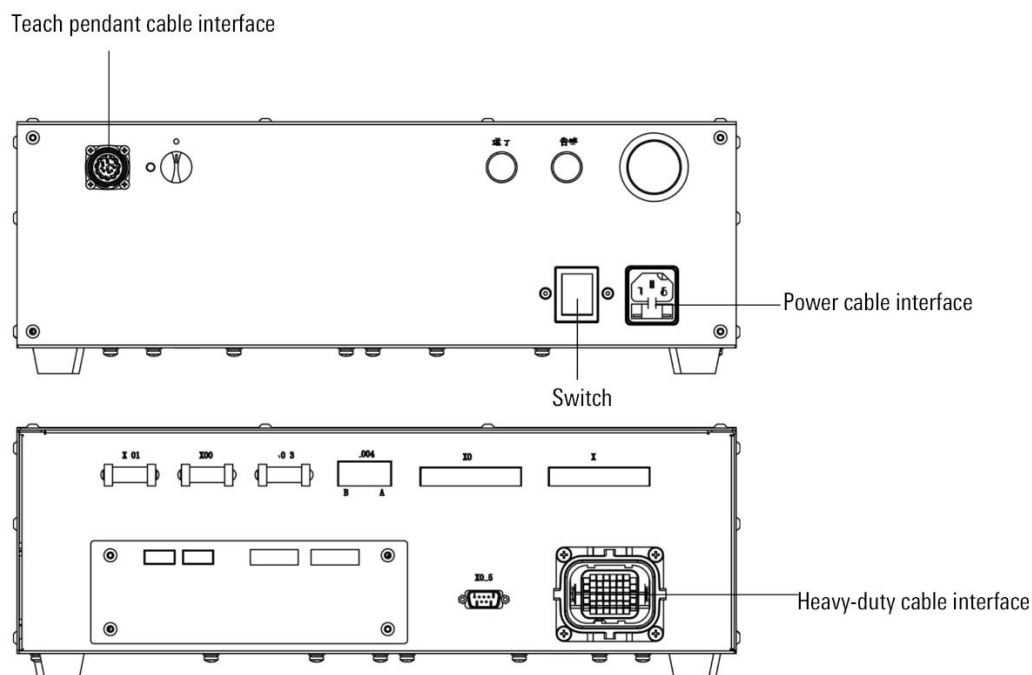

Figure 5-4 Schematic diagram of control cabinet

As described in section 4.2 of this manual, the heavy-duty connector on the manipulator is connected to the control cabinet through a heavy-duty line (refer to Figure 5-4). The two ends of the heavy-duty line are respectively used to connect the manipulator and the control cabinet. The heavy-duty line does not distinguish between the manipulator end and the control cabinet end (see Figure 5-5).

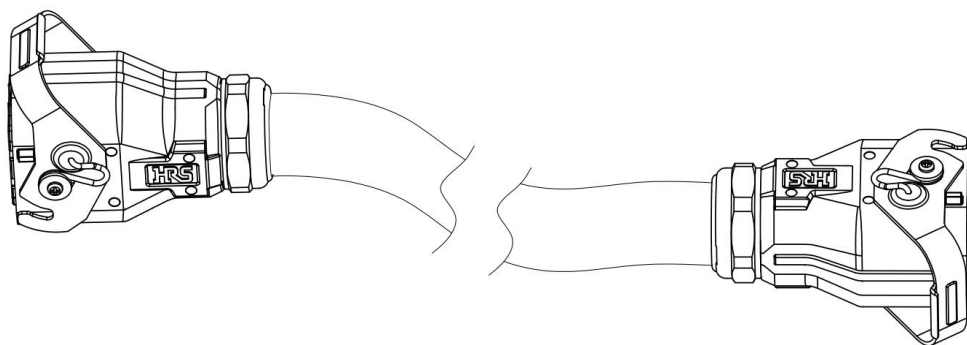

Figure 5-5 Schematic diagram of heavy load line

Connection steps:

- Step1. Connect the manipulator, insert one end of the heavy-duty line plug into the heavy-duty line connection port of the manipulator (see Figure 5-6), and fasten the lock.
- Step2. Connect the control cabinet, insert the plug at one end of the heavy load line into the heavy load line connection port of the control cabinet (see Figure 5-7), and fasten the lock.

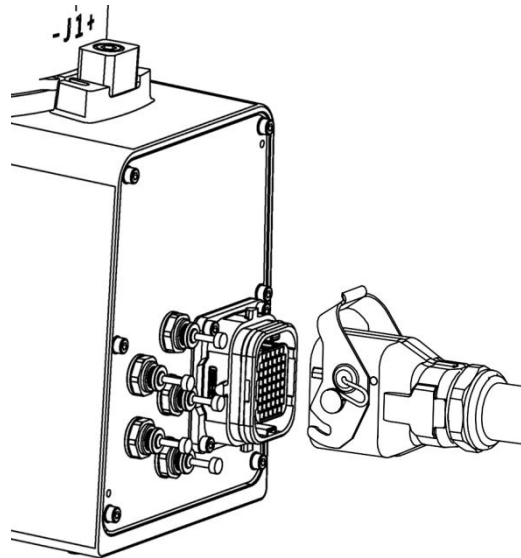

Figure 5-6 Manipulator heavy load line connection interface

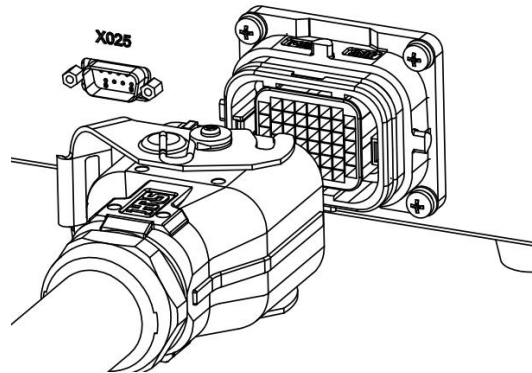

Figure 5-7 Control cabinet heavy-duty connector interface

### 5.3 Power connection

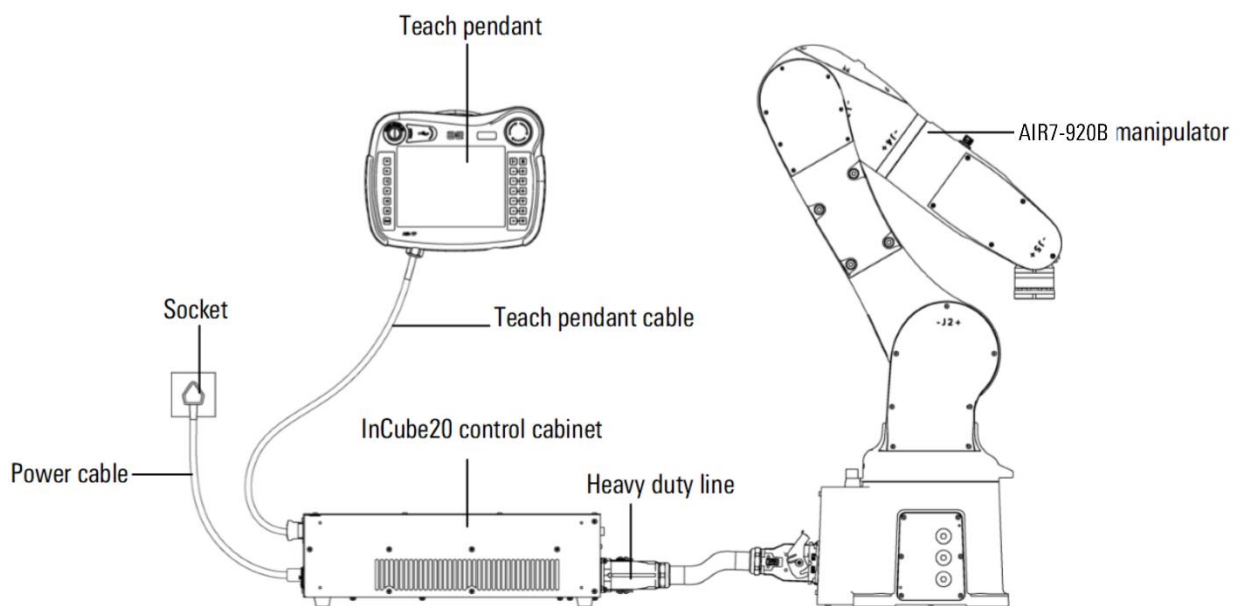

Figure 5-8 industrial robot system wiring overview

Both ends of the power cord are used to connect the control cabinet and the power supply (see Figure 5-8).

Connection steps:

Step1. Connect the control cabinet, and insert the power cord shape plug into the power cord connection port of the control cabinet (see Figure 5-9).

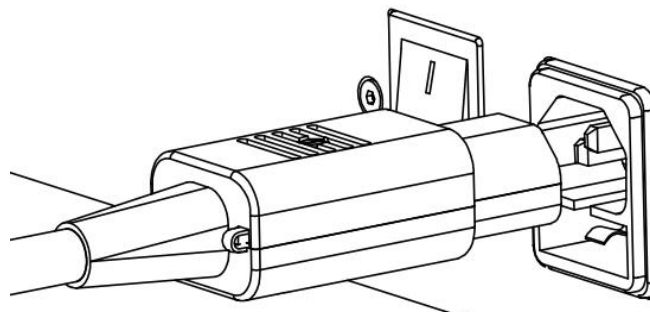

Figure 5-9 Power cord connection interface

Step2. Connect the power supply and insert the three-head plug of the power cord into the power socket.

Step3. Confirm that the on-site power supply voltage and current meet the requirements of the control cabinet (provide 220VAC voltage and meet at least 10A peak current load).

Step4. Confirm that the system short-circuit module of the control cabinet is connected normally (X005 in Figure 5-10 is the normal connection state).

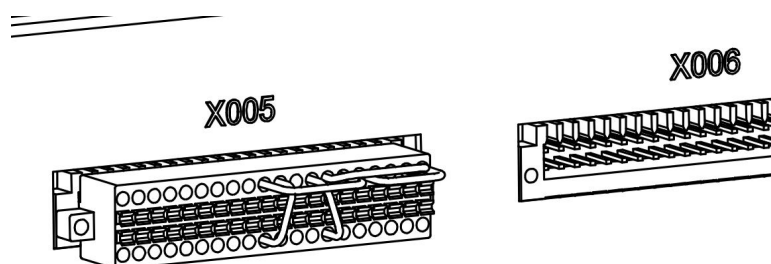

Figure 5-10 System short circuit module

Step5. After powering on, switch the rocker switch from "0" to "I" (refer to Figure 5-11), start the control cabinet, at the same time the switch's own light is on, and the teach pendant starts.



Figure 5-11 Control cabinet power switch

Step6. Before powering off, please confirm that the program has stopped running. After the motor is powered off, turn off the switch on the control cabinet. It is forbidden to unplug the power cord directly.

## 6 Job description

### 6.1 Safe operation

#### 6.1.1 Dimensions and working range of each axis

The movement range of each axis of the manipulator is shown in the following Table 6- 1.

Table 6- 1 manipulator's movement range of each axis

Axis number	Movement range (°)
J1*	-170 ~ +170
J2	-100 ~ +135
J3	-120 ~ +156
J4	-200 ~ +200
J5	-135 ~ +135
J6	-360 ~ +360

The operating range of the manipulator is shown in Figure 6-1.

When installing peripheral equipment, pay attention to avoid interfering with the main part of the robot and the range of motion. Unit: mm.

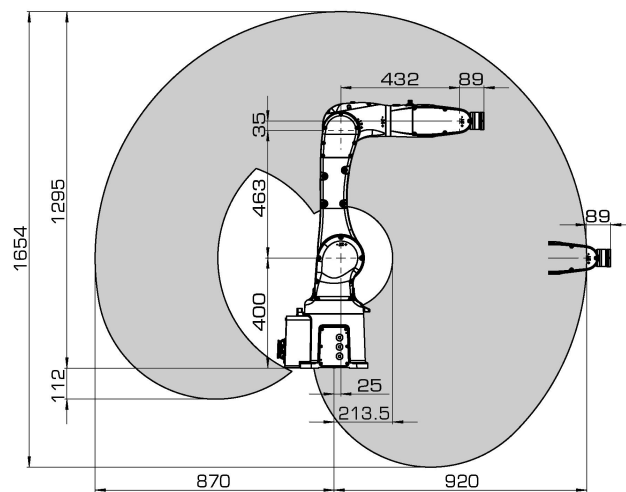

(a) Side view

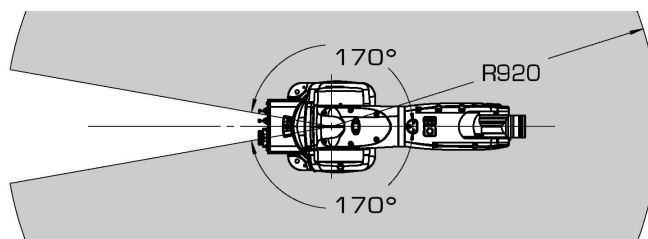

(b) Top view

Figure 6-1 manipulator working range



## 6.1.2 Mechanical limit

Each axis of the manipulator is equipped with a zero point and a movable range. As long as the origin position is not lost due to servo system abnormalities and system errors, the robot is controlled to move within the movable range. In addition, in order to further ensure safety, an optional mechanical brake is also provided on the 1 axis to limit the movable range. There is a sliding limit device inside the 4-axis mechanical body as its mechanical limit.

Figure 6-2 shows the position of the mechanical brake.

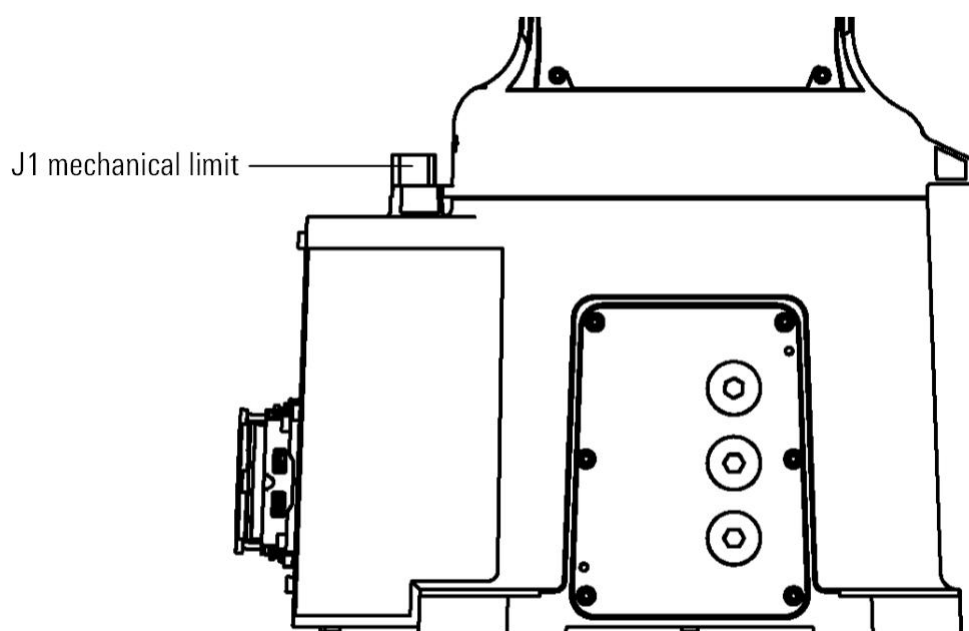

Figure 6-2 Mechanical brake on manipulator



Warning

Do not modify the mechanical brake, etc., otherwise the robot may not stop normally

## 6.1.3 Stop mode

According to the definition of stop function in 9.2.2 of GB5226.1-2008 "Mechanical and Electrical Safety-Part 1: General Technical Conditions", combined with the specific design of the robot, the definition of 3 stop modes and corresponding descriptions are shown in Table 6-2 :

Table 6- 2 Stop method and corresponding instructions

Type	Description
STOP0	Case1 CCB alarm stop0 indicate, DCB execution stops immediately without keeping track, after which the CCB delay control cuts off the power through the thyristor enable, which is an uncontrollable stop
	Case2 DCB has an uncontrollable fault, triggering a free stop or brake stop, which is an uncontrollable stop
	Case3 Sudden external power failure, DCB cannot perform immediate stop, trigger brake to stop, it is an uncontrollable stop
STOP1	Make the robot stop quickly and maintain the current planned path. When the robot stops, control the drive serve_off and cut off the power supply through the thyristor, which is a controlled stop

Type	Description
STOP2	Make the robot stop quickly and need to maintain the current planned path. When the robot stops, do not serve_off or cut off the power supply, which is a controlled stop

## 6.2 Calibration

### 6.2.1 When is calibration required

When the following situations occur in the manipulator, recalibration is required:

- There has been maintenance such as motor replacement or pulley removal.
- The encoder battery has been replaced.
- The encoder cable of the motor is loose or reinstalled
- The manipulator has experienced a strong collision.
- The control cabinet or control system (such as industrial computer) is replaced.

### 6.2.2 Calibration position of each axis



Prompt

Please refer to "Industrial Robot System Quick Start Manual" for detailed operation method during calibration.

The calibration position of each axis of the manipulator is shown in Figure 6-3 below. Except for the calibration of the J3 axis, which is 90°, the other axes are all 0°.

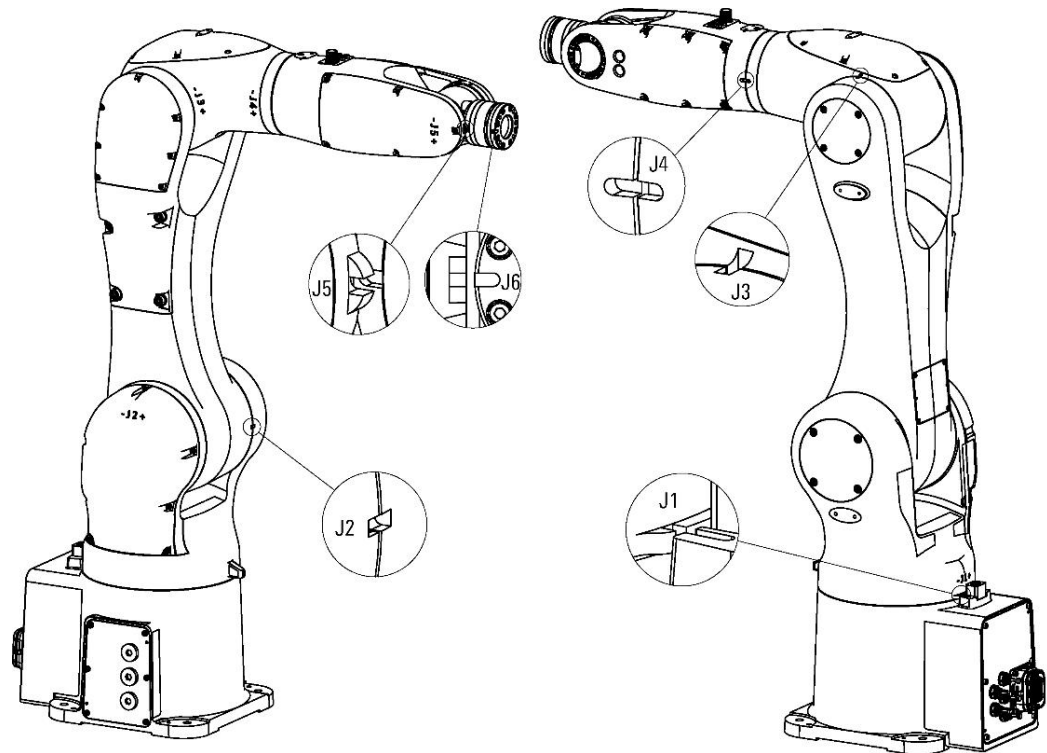

Figure 6-3 Schematic diagram of the zero point of each axis of SOT7-920B



Warning

- The robot calibration must always be performed under the same temperature conditions to avoid errors caused by thermal expansion and contraction.
- The industrial robot must be calibrated sequentially from the J1 axis to the J6 axis.

### Calibration under high repeat positioning accuracy

In the working process of the manipulator, when only high repeat positioning accuracy is required, there is no requirement for path positioning accuracy. According to the zero-point calibration position of each axis shown in Figure 6-4, use naked eye observation to make the zero-point position of each axis aligned.

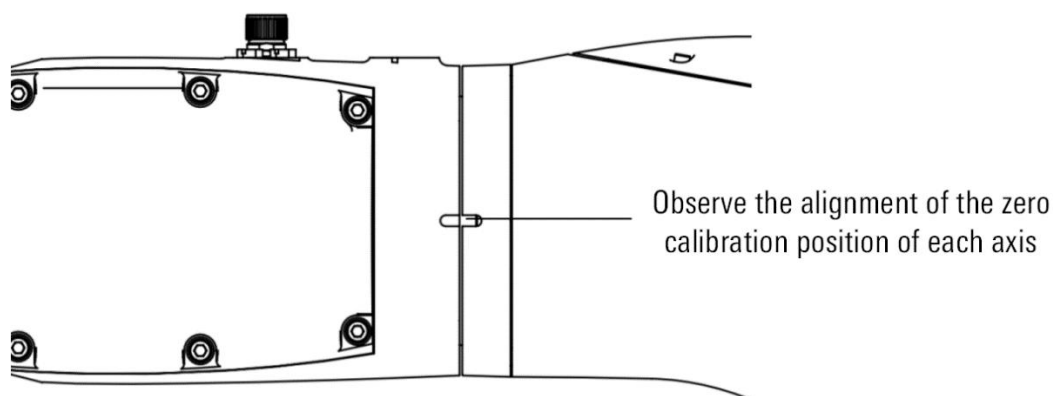

Figure 6-4 Observe the zero calibration method with naked eyes



Warning

During the calibration process of the manipulator, the speed should be reduced as much as possible. The operator shall not enter the working range of the robot. After the robot stops moving each time, observe the alignment of the zero-point scale on the axis position.

### Calibration when there are rough requirements for path positioning accuracy

When the path positioning accuracy is roughly required, use the calibration block to calibrate, as shown in Figure 6-5.

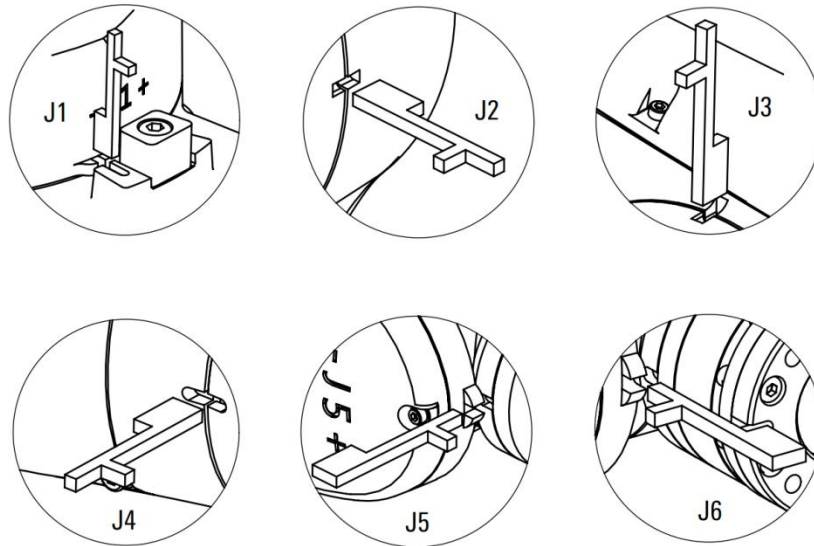

Figure 6-5 Calibration method of zero calibration block

<p>Warning</p>	<p>During the calibration process of the manipulator, the speed should be reduced as much as possible. The operator shall not enter the working range of the robot. After the robot stops moving each time, observe the alignment of the zero-point scale on the axis position.</p>
<p>Caution</p>	<p>When using the calibration block to calibrate the manipulator, first observe the basic alignment of the calibration groove with the naked eye, reduce the operating speed of the manipulator to the lowest manual gear, fine-tune the shaft position, use the calibration block to calibrate, after several fine adjustments, the calibration block can be inserted into two calibration slots at the same time. As shown in Figure 65.</p>

### Calibration under high path positioning accuracy requirements

When the manipulator requires high path positioning accuracy, the angle and length of each axis need to be accurately calibrated and compensated, and you need to contact our company to use special equipment for calibration.

#### 6.2.1 Movement direction of each axis

For the industrial robot manipulator with 6 degrees of freedom, the definition of its movement direction is shown in Figure 6-6.

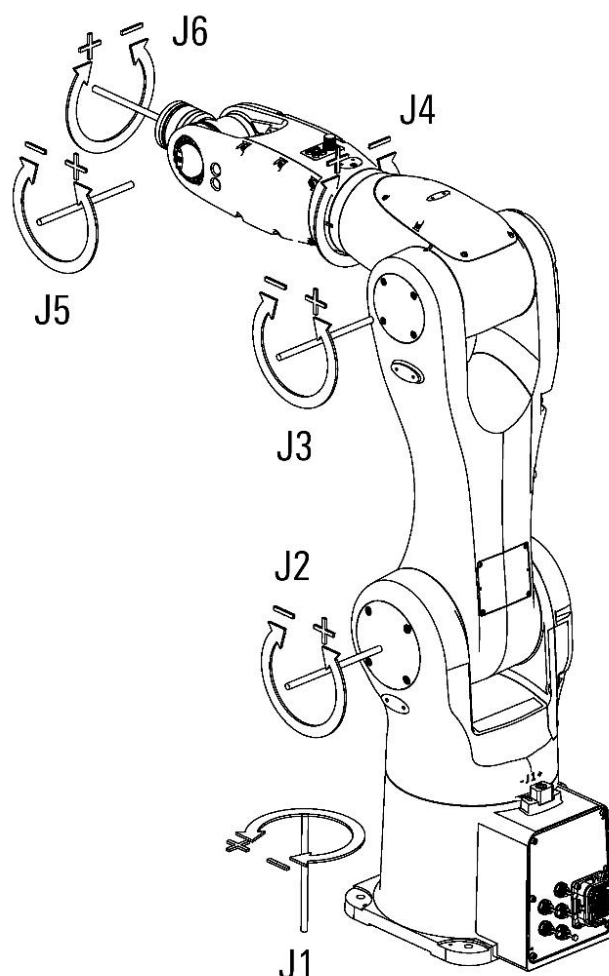

Figure 6-6 Manipulator axis movement direction

## 6.2.2 Speed of each axis

The maximum angular velocity of each axis of the manipulator is shown in Table 6-3.

Table 6-3 Maximum angular velocity of each axis of manipulator

Axis number	Maximum allowable angular velocity (°/s)
J1	380
J2	320
J3	390
J4	490
J5	565
J6	815

## 6.3 Output flange size

output flange specifications and connection dimensions and schematic diagrams are shown in Table 6-4 and Figure 6-7. For screw tightening torque, refer to Appendix B, Screw Strength and Screw Tightening Torque Table (Nm).

Table 6- 4 output mechanical interface specifications

Positioning circle diameter	31.5mm or 63mm
Diameter of threaded hole indexing circle	50mm
Screw grade	12.9 level
Screw diameter	M6
Screw diameter	4
Positioning pin	6mm
Screw standard	GB/T 70.1-2000

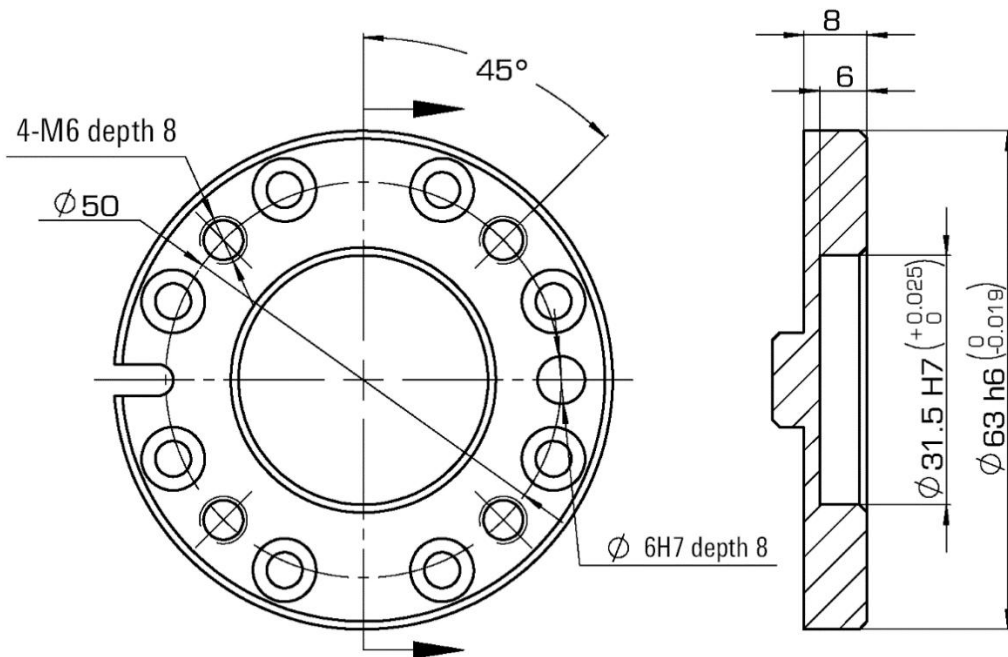



Figure 6-7 Schematic diagram of wrist flange size of manipulator



Warning

When installing the fixture, the screws and positioning pins used should fully consider the depth of the threaded hole and the pin hole. The installation length is prohibited to exceed the depth of the threaded hole (8mm) and the depth of the pin hole (8mm), otherwise it will damage the wrist of the manipulator.

## 6.4 Load and installation method

### Manipulator wrist load installation

The load line diagram of the wrist of the manipulator is shown in Figure 6-8.

Installation requirements:

- For loads whose mass does not exceed 1kg, 3kg, 5kg, and 7kg, the center of mass positions  $L_{xy}$  and  $L_z$  should be within the range of the corresponding wire frame shown in Figure 6-8(b); Figure 6 8(a) defines  $L_{xy}$  and  $L_z$  Meaning,  $L_{xy}$  represents the distance between the projection position of the load centroid on the flange plane and the origin, and  $L_z$  represents the distance between the load centroid projection position on the flange axis and the origin.
- 4-axis allows wrist torque less than 12Nm, 5-axis allows wrist torque less than 12Nm, and 6-axis allows wrist torque less than 6Nm.

- 4-axis allowable load moment of inertia is less than  $0.3\text{kgm}^2$ , 5-axis allowable load moment of inertia is less than  $0.3\text{kgm}^2$ , and 6-axis allowable load moment of inertia is less than  $0.1\text{kgm}^2$ .

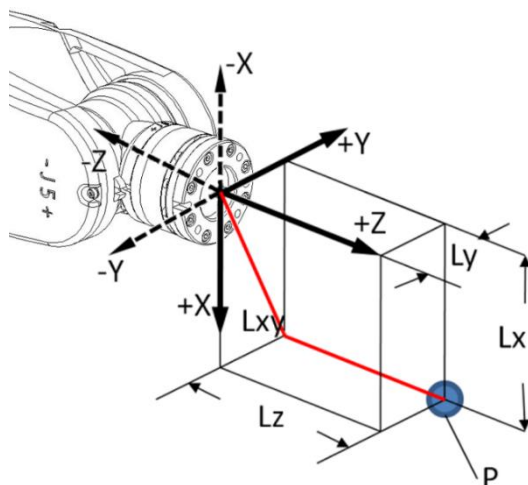

(a) Schematic diagram of the positional relationship between the end flange and the load centroid

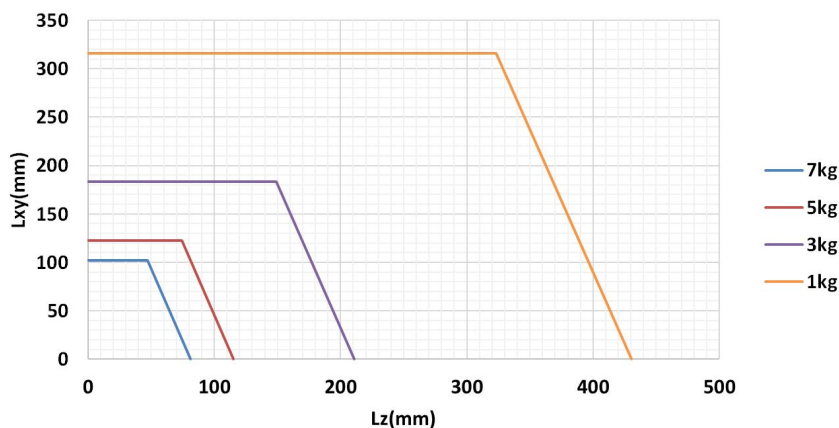

(b) Schematic diagram of allowable range of load centroid position

Figure 6-8 Schematic diagram of manipulator wrist load centroid position

### Manipulator 3-axis elbow equipment installation

The equipment mounting hole specifications and dimensions of the J3 axis elbow of the manipulator are shown in Figure 6-9.

Installation requirements:

- The elbow and wrist of the manipulator can be equipped with external equipment weighing no more than 7kg.
- The center of mass of the elbow load must be located inside the  $50\text{mm} \times 80\text{mm}$  area shown in Figure 6-9.
- The height of the center of mass should not exceed 50mm from the height of the mounting surface.
- The reliability of the installation must be fully considered when the equipment is installed. It is recommended to install with 12.9 grade screws according to the specified torque, and apply thread glue to the threads. Otherwise, the long-term operation may loosen or even break, causing accidents.

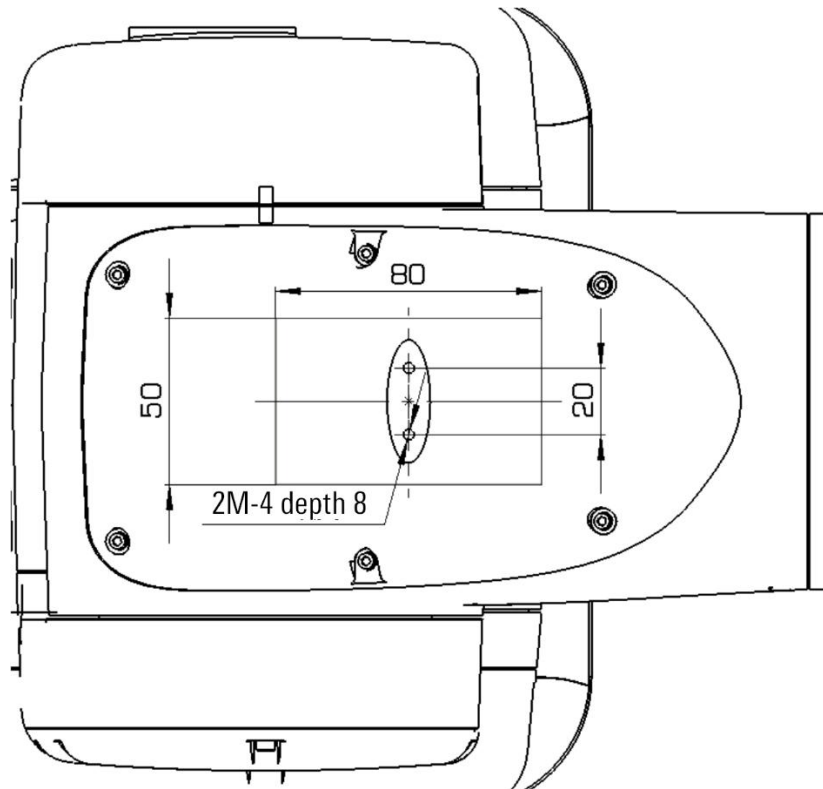



Figure 6-9 Schematic diagram of elbow load interface size of manipulator

 Warning	<ul style="list-style-type: none"> <li>■ Since it may adversely affect the safety and function of the manipulator, never add machining holes and screw holes to the main body of the manipulator.</li> <li>■ When installing the equipment, the screw used should fully consider the depth of the threaded hole, and the installation length is prohibited to exceed the depth of the threaded hole (6mm), otherwise it will damage the elbow of the manipulator.</li> <li>■ The elbow load center must not exceed the above value, otherwise the manipulator may give an alarm, fail to work normally, or reduce the working life.</li> <li>■ When installing equipment at the elbow of the manipulator, pay attention to avoid interference with the manipulator body and cables, which may cause the body cable to break and cause unexpected serious failures and consequences.</li> </ul>
--	--

### Fixed position of manipulator arm

The installation hole specifications and dimensions of the manipulator arm are shown in Figure 6-10.



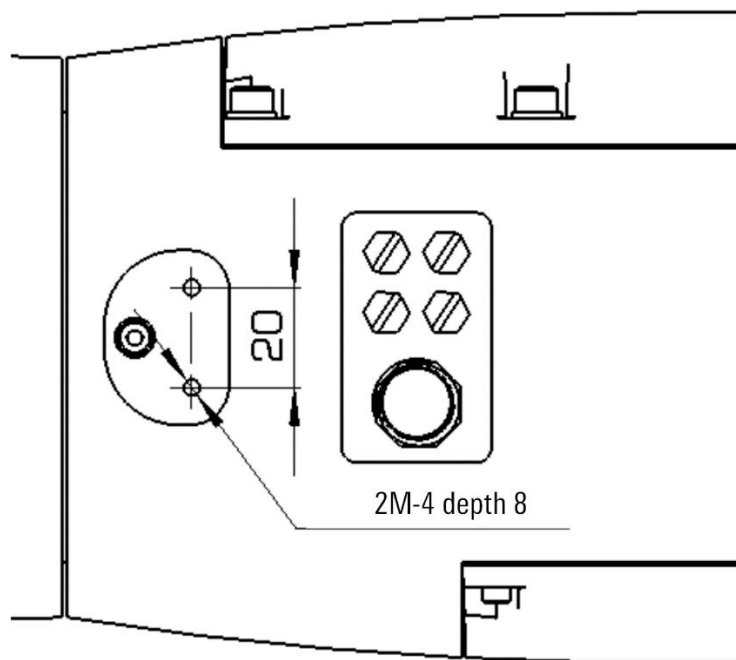

(a) Mounting hole specifications on the elbow side of the forearm

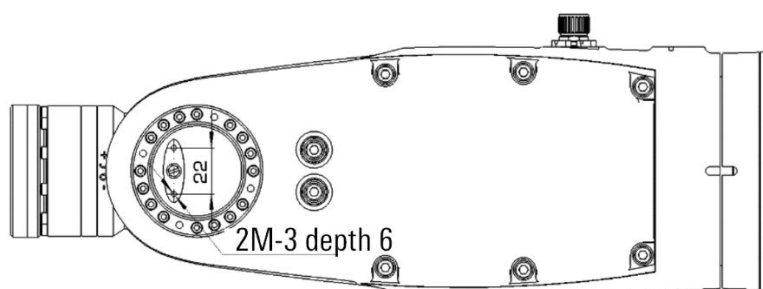

(b) Mounting hole specifications on the wrist side of the forearm

Figure 6-10 Dimension drawing of forearm interface of manipulator

### Fixed position of manipulator upper arm and J1 axis manipulator

The installation hole specifications and dimensions of the manipulator upper arm and the J1 axis manipulator are shown in Figure 6-11 and Figure 6-12.

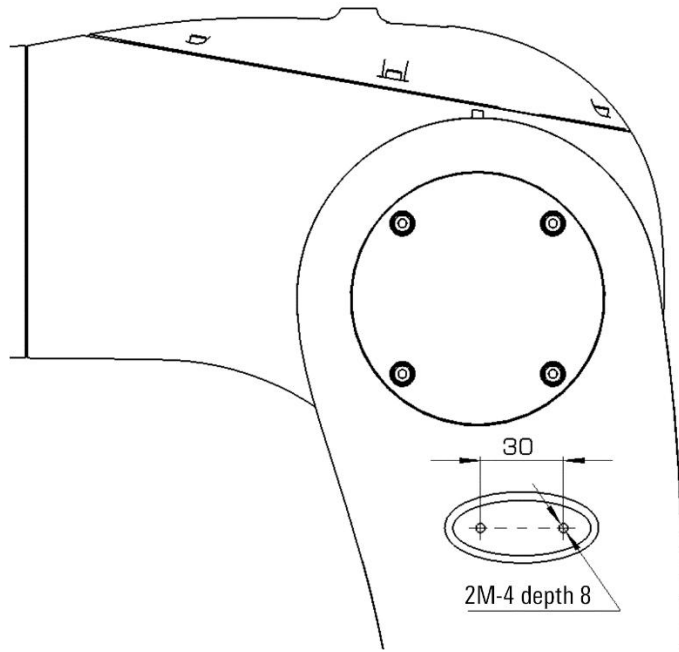

Figure 6-11 upper arm interface size diagram

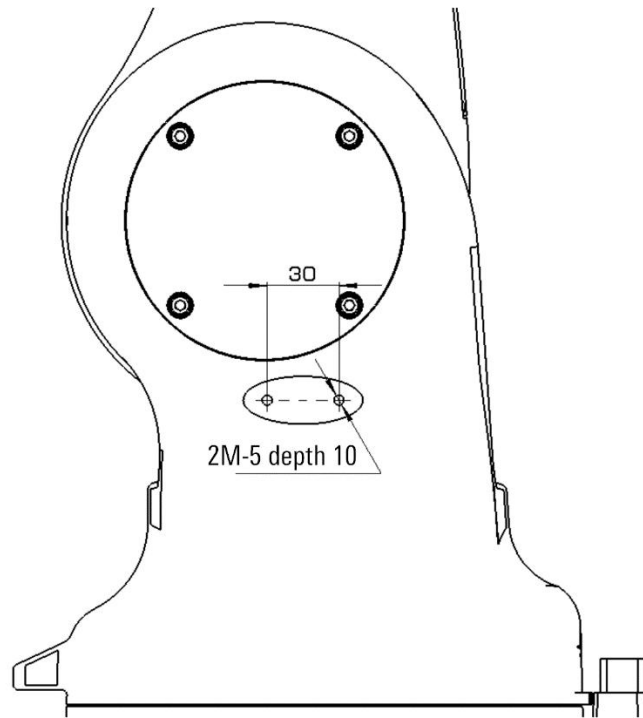

Figure 6-12 J1 axis manipulator interface size drawing



Warning

- When installing the equipment, the screws used should fully consider the depth of the threaded hole, and the installation length is prohibited to exceed the depth of the threaded hole, otherwise it will damage the internal components of the manipulator or cables.
- The above parts are designed for cable fixing. If you need to install equipment, you need to ensure that the total load is less than 7kg.
- The reliability of the installation must be fully considered when the equipment is installed. It is recommended to install with 12.9 grade screws according to the specified torque, and apply thread glue to the threads. Otherwise, the long-term operation may loosen or even break, causing accidents.



## 7 General Rules for Maintenance

---

This manual is about the preventive maintenance of the manipulator. For a complete set of industrial robot system maintenance, it should also include:

- For the maintenance of the control cabinet, please refer to the "inCube20 Control Cabinet Manual" of our company.
- For maintenance of the end effector, please refer to the relevant manual (ie the relevant manual of the end effector provided by the user).



Warning

- Before reading the general safety instructions and safety precautions, absolutely must not perform any maintenance operations, and maintenance operations can only be completed by appropriately trained technicians.
- The main goal of preventive maintenance is to ensure the maximum use of the manipulator system. Every scheduled and properly implemented regular maintenance should help achieve this goal. If regular maintenance fails to achieve the goal of shortening device downtime, it is unnecessary maintenance and waste.
- The robot system is designed to work under quite harsh conditions and only requires minimal maintenance. Nonetheless, daily inspections and regular maintenance must be carried out at given intervals.
- The time interval in the maintenance table is a recommended value. The actual time interval required to maintain the manipulator may vary due to factors such as the actual working environment of the manipulator.
- When implementing routine maintenance or maintenance, many preventive measures must be kept in mind to avoid introducing additional errors or dangers into the system.
- For well-functioning equipment, do not implement more maintenance than required regular maintenance.
- Before starting the maintenance program, all surfaces should be wiped clean.
- In order to avoid unnecessary pollution caused by dust and other sundries, the exterior of the control cabinet door and manipulator cover should be cleaned before opening.



## 8 Preventive maintenance

### 8.1 Daily maintenance

When operating the manipulator every day, check the items shown in Table 8- 1.

Table 8- 1 Daily maintenance items of the manipulator

No.	Check item	Check essentials
1	Vibration, sound, motor heating	Whether there is abnormal vibration or noise on each axis, and whether the motor temperature is abnormally high.
2	Whether the positioning accuracy changes	Check whether it deviates from the last start position and whether there is a deviation in the stop position
3	Operation confirmation of peripheral equipment	Confirm that the actions of the manipulator and peripheral equipment are consistent with the instructions

### 8.2 First maintenance

The operation machine shall run for the first time 320 hours or 1 month (whichever is shorter), and the following items shall be inspected and maintained. As shown in Table 8- 2:

Table 8- 2 Manipulator First Maintenance Project.

No.	Inspection item	Main points of inspection
1	Whether the cable and cable sheath of the operator are damaged differently and whether the motor connector is loose	Observe the cable activity part of the manipulator, check whether the cable is damaged, whether the cable is bent or distorted locally, check whether the cable sheath is damaged or not, and check whether the motor connector is loose (Note 1)
2	End effector mounting screws	Check whether the bolts are loose and tighten them with a torque wrench (Note 2)
3	Clean all parts of the manipulator	Clean and maintain the parts of the manipulator, and check whether the parts are damaged (Note 3).
4	Whether the terminal actuator cable is damaged or not	Inspect the cable for damage, and the cable sheath is damaged
5	Whether the timing belt is worn	Check the timing belt for wear, elongation, and breakage (Note 4)
6	Check whether the limit block at the J1 axis is damaged	Check whether the limit block is loose, collision damage, etc.

Note 1:

Check and RepSOT Points

- Cables and cable sheaths inside the base of the manipulator (need to remove the electrical installation plate).
- The internal cable and cable sheath of the manipulator arm and the J1 axis body.
- Manipulator connection cable, ground terminal, user cable connector.

**Confirmation**

- Check whether the line sheath is cracked or worn. If the sheath is damaged, replace it.
- Check whether the grease on the surface of the cables inside the J1 shaft body and the inside cables of the upper arm has disappeared. If the grease is about to disappear, replenish it.
- Check whether the wiring is worn out, and replace the internal wires if they can be seen.
- Circular connector: turn it by hand to see if it is loose.
- Grounding terminal: confirm whether it is loose.

Note 2:

**Fastening part**

- Tighten the end effector mounting bolts, manipulator fixing bolts, etc.
- The external connection screws of the manipulator, especially the connection screws of each shaft and the reducer.
- For tightening torque, please refer to the recommended values in the appendix of this manual.

Note 3:

**About cleaning**

- The parts that need to be cleaned, the accumulation of dust and splashes on the surface, should be cleaned regularly.
- Special attention should be paid to cleaning between the rotating parts of the J5 axis of the wrist to remove debris in time.
- Check if there is oil leaking from the reducer or gear box.
- After wiping off the oil, if the oil is still visible after 1 day, there may be an oil leak.

Note 4:

**About timing belt maintenance**

- After disassembling the outer shell of the forearm, observe whether the timing belt is worn or damaged. For removing the cover, please refer to Chapter 9.4 in this manual.
- Observe whether there is white hSOT inside the teeth of the timing belt, whether the belt side is worn, whether the belt teeth are crushed, whether the belt body is broken, whether the belt body is stretched (decreased preload), etc.

## 8.3 Regular maintenance

### Regular maintenance for 960 h (3 months)

The following check and repSOT items shall be done for manipulator after the 960 h or 3 months (whichever comes first). As shown in Table 8- 3.

Table 8- 3 Maintenance Items for 960 h (3 months)

No.	Check Item	Essentials
1	Cleaning of control cabinet vent	Remove the dust accumulated at control cabinet vent
2	Cleaning of manipulator	Wipe off the dirt and remove the accumulated splash, dust, chip, etc.

### Regular maintenance for 1,920 h (6 months)

The following check and repSOT items shall be done for manipulator after the 1,920 h or 6 months (whichever comes first). As shown in Table 8- 4.

Table 8- 4 Maintenance Items for 1,920 h (6 months)

No.	Check Item	Essentials
1	Check whether the manipulator cable and cable sheath are damaged	See the first maintenance in Chapter 8.2.
2	Whether the timing belt is worn out.	Check the synchronous belt for wear, elongation and breakage

### Regular maintenance for 3,840 h (1 year)

The following check and repSOT items shall be done for manipulator after the 3,840 h or 1 year (whichever comes first). As shown in Table 8- 5

Table 8- 5 Maintenance Items for 3,840 h (1 year)

No.	Check Item	Essentials
1	Check whether the manipulator cable and cable sheath are damaged	See the first maintenance in <i>Chapter 8.2</i>
2	Fasten the main external bolts	See the first maintenance in <i>Chapter 8.2</i>
3	Clean the parts of manipulator	See the first maintenance in <i>Chapter 8.2</i>
4	Check whether the cables of end effector are damaged	See the first maintenance in <i>Chapter 8.2</i>
5	Replacement of Synchronous Belt	See the first maintenance in <i>Chapter 8.2</i>
6	Check whether the limit rubber block of J1 axle is damaged	See the first maintenance in <i>Chapter 8.2</i>

### Regular maintenance for 7,860 h (2 years)

The following check and repSOT items shall be done for manipulator after the 7,860 h or 2 years (whichever comes first). As shown in Table 8- 6:

Table 8- 6 Maintenance Items for 7,860 h (2 years)

No.	Check Item	Essentials
1	Battery Replacement	See <i>the first maintenance in Chapter 9.3</i>

### Regular maintenance for 11,520 h (3 years)

The following check and repSOT items shall be done for manipulator after the 11,520 h or 3 years (whichever comes first). As shown in Table 8- 7:



Table 8- 8 Maintenance Items for 11,520 h (3 years)

No.	Check Item	Essentials
1	Replacement of Synchronous Belt	See <i>the first maintenance in Chapter 8.2.</i>

### Regular maintenance for 15,360 h (4 years)

The following check and repSOT items shall be done for manipulator after the 15,360 h or 4 years (whichever comes first). As shown in Table 8- 9:

Table 8- 9 Maintenance Items for 15,360 h (4 years)

No.	Check Item	Essentials
1	Replace the internal cables of manipulator	Replace the manipulator cable, please consult with us

### Regular maintenance for 19,200 h (5 year)

The manipulator shall be overhauled with many parts replaced for 5 years or 192,000 h (whichever comes first). Please contact us. As shown in Table 8- 10:

Table 8- 10 Maintenance Items for 19,200 h (5 years)

No.	Check Item	Essentials
1	Manipulator overhaul	Please consult with us

## 9 Project maintenance process

---

### 9.1 Cleaning the manipulator

In order to ensure the long-term operation of the robot, the manipulator should be cleaned regularly every 960 hours or 3 months of operation (whichever is shorter).

Cleaning steps:

Step1. Adjust the robot to the zero position of each axis.

Step2. To prevent danger, turn off the power, hydraulic and SOT pressure sources connected to the robot.

Step3. Use a vacuum cleaner to clean the manipulator, or wipe with a cloth.

Step4. After ensuring that all safety conditions are met, proceed with the follow-up work of the manipulator.



Caution

- It is forbidden to use water jet on the manipulator, especially the joints and seals.
- It is forbidden to use compressed SOT to clean the manipulator.
- It is forbidden to remove any manipulator protection device
- Do not use solvents to clean the manipulator

### 9.2 Check and repSOT cables

To ensure that the robot can run for a long time, every 1920 hours or 6 months of operation (whichever is shorter), the manipulator cable should be checked.

#### Check and repSOT the internal cables of the base

Maintenance steps:

Step1. Remove the lower cover, as shown in Figure 9-1, the cables inside the base can be observed.

Step2. Check whether there is abrasion or damage on the fixing place between the cable and the fixing plate.

Step3. Check whether the internal cables are worn or damaged.

Step4. If there are cracks, wear or damage, please contact our company for replacement in time.

Step5. Install the cable as it is inside the base.

Step6. Install the lower cover, paying attention to the sealing gasket to be put back as it is.

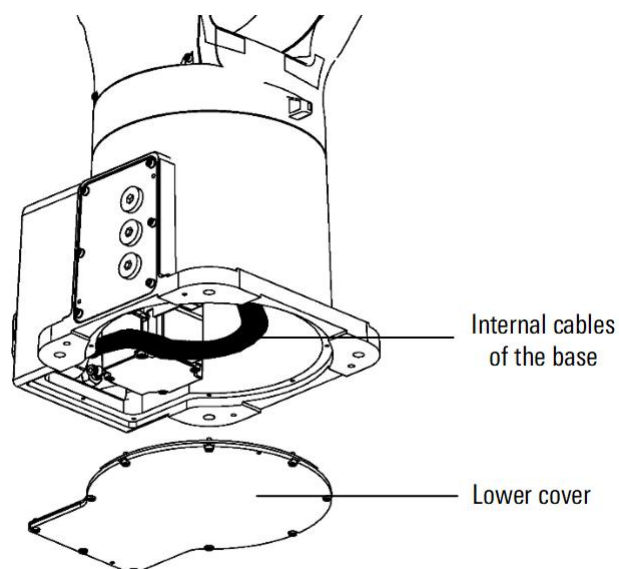

Figure 9-1 Cable maintenance inside the base

### RepSOT the internal cables of the J1 shaft body

Maintenance steps:

- Step1. Remove the J1 shaft body cover, as shown in Figure 9-2.
- Step2. Check whether the connection between the cable and the bracket is reliable.
- Step3. Check whether there is abrasion or damage at the fixing place between the cable and the bracket.
- Step4. If there are cracks, wear or damage, please contact our company for replacement in time.
- Step5. Check whether the grease on the inner cable surface has disappeared.
- Step6. If the grease on the cable surface disappears, it should be refilled in time.
- Step7. Install the J1 shaft body cover, pay attention to the sealing gasket should be put back as it is.

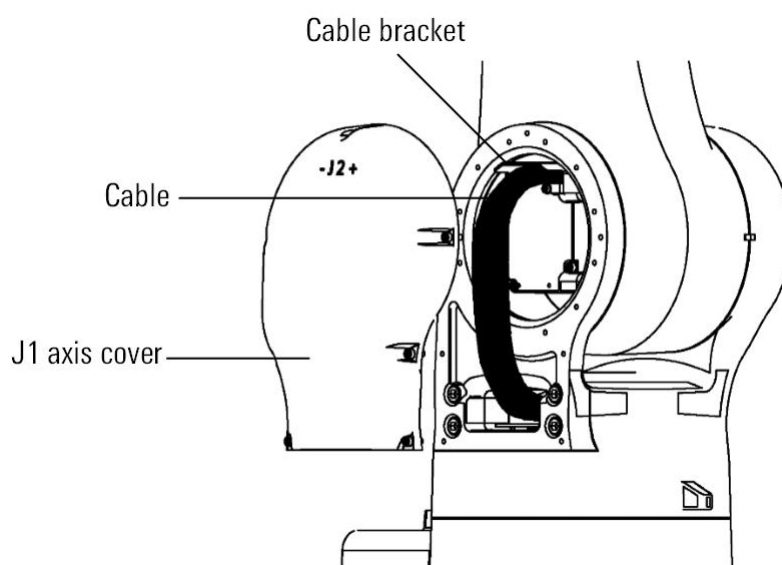

Figure 9-2 J1 shaft internal cable maintenance

### RepSOT the internal cables of the upper arm

Maintenance steps:

- Step1. Remove the cover, as shown in Figure 9-3.
- Step2. Check whether the connection between the cable and the bracket is reliable.
- Step3. Check whether the fixing place between the cable and the cable bracket is worn or damaged.
- Step4. If there are cracks, wear or damage, please contact our company for replacement in time.
- Step5. Check whether the grease on the inner cable surface has disappeared.
- Step6. Check whether the grease on the inner cable surface has disappeared.
- Step7. Install the cover plate, paying attention to the sealing gasket to be put back as it is.

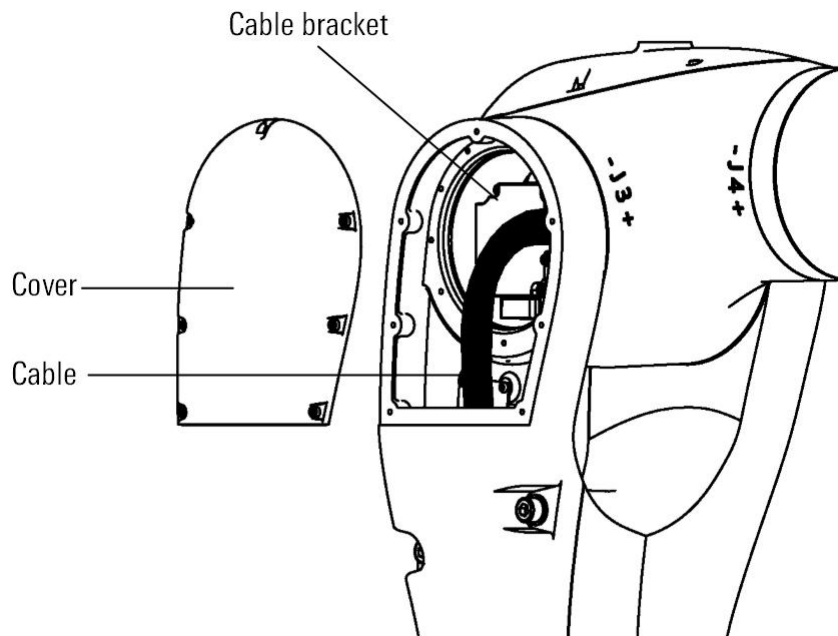

Figure 9-3 Maintenance of internal cables of the upper arm



Please entrust the service department of our company to replace the internal cables of the manipulator ; using unqualified cables may cause the robot to fail to work normally.

## 9.3 Replacing the battery

The position data of each axis of the manipulator is saved by the encoder battery. Every 7860 hours or 2 years of operation (whichever is shorter), or the driver prompts A2 alarm, the battery should be replaced in time.

Replacement steps:

- Step1. Adjust the robot to the calibration state.
- Step2. To prevent danger, turn off the power, hydraulic and SOT pressure sources connected to the robot.

- Step3. Remove the side cover of the base of the manipulator, and pay attention to the cables connected inside to prevent damage caused by pulling forcefully.
- Step4. Remove the battery box fixing sheet metal from the right cover, you can see the battery, as shown in Figure 9-4.
- Step5. Remove the old battery from the battery box, and put the new battery into the battery box. Note that the positive and negative polarity of the battery is consistent with the old battery.
- Step6. Replace the battery box fixing sheet metal back to the side cover of the base.
- Step7. Put back the base side cover, paying attention to the sealing gasket as it is.
- Step8. After ensuring that all safety conditions are met, perform calibration and testing of the manipulator.

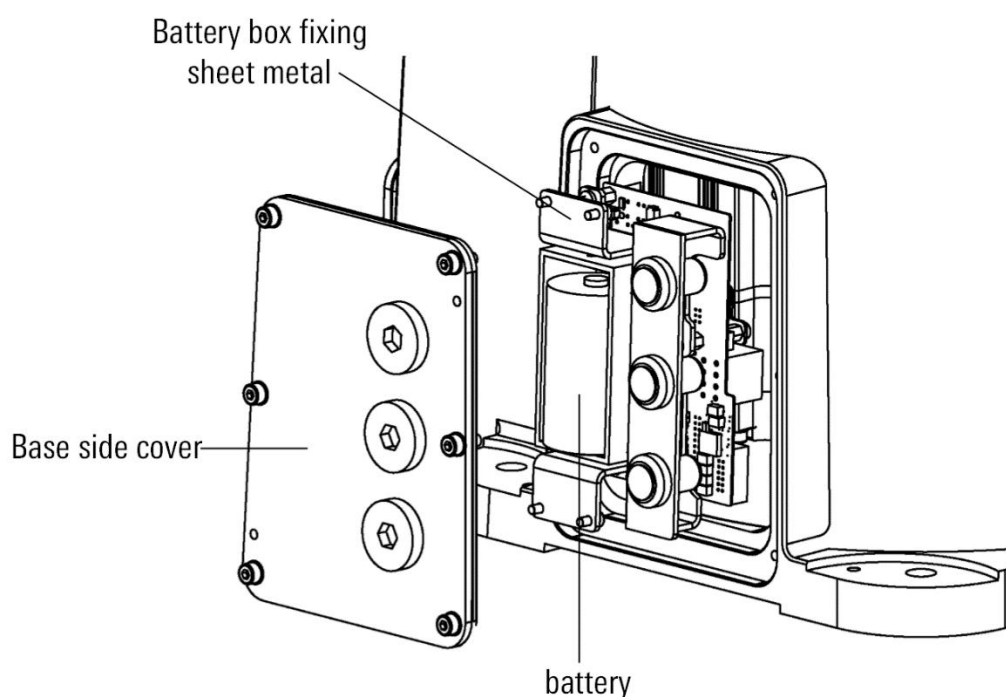

Figure 9-4 Schematic diagram of battery replacement

## 9.4 Replace timing belt

Every time the manipulator runs for 3840 hours or 1 year (whichever is shorter), it is necessary to replace the J1, J5 and J6 axis timing belts. For synchronous belt models, see Table 9- 1.

Table 9- 1 Manipulator timing belt model

Manipulator model	Timing belt position	Synchronous belt model
SOT7-920B	J1 axis inside the base	Gates, 375-5GT-9
SOT7-920B	J5 axis inside forearm	Gates, 360-3GT-6
SOT7-920B	J6 axis inside forearm	Gates, 360-3GT-6

When replacing J5 and J6 timing belts, see Table 9- 2 for the manipulator attitude.

Table 9- 2 Manipulator replacement timing belt attitude

J1	J2	J3	J4	J5	J6
Arbitrary posture	0°	90°	0°	90°	Arbitrary posture

### Replace J5J6 axis timing belt

The replacement process is as follows:

- Step1. Run the manipulator to the posture shown in Table 9- 2.
- Step2. Turn off the power to the control device.
- Step3. Remove the manipulator cover and five M3 screws, as shown in Figure 9-5.
- Step4. Loosen the mounting screws of the motor assembly, as shown in Figure 9-6.
- Step5. Move the motor pulley assembly, remove the old timing belt, and install the new timing belt.
- Step6. Preliminarily tighten the motor base screw M4.
- Step7. Adjust the screw position, adjust the timing belt to the proper pre-tightening force and installation deflection (refer to Figure 9-7), the recommended pre-tightening force is 14.6N, and the installation deflection is 2.6mm.
- Step8. Install the motor base screw M4 with the specified torque.
- Step9. Install the manipulator cover and apply sealant on the joint.
- Step10. Calibrate the J5J6 axis of the manipulator.

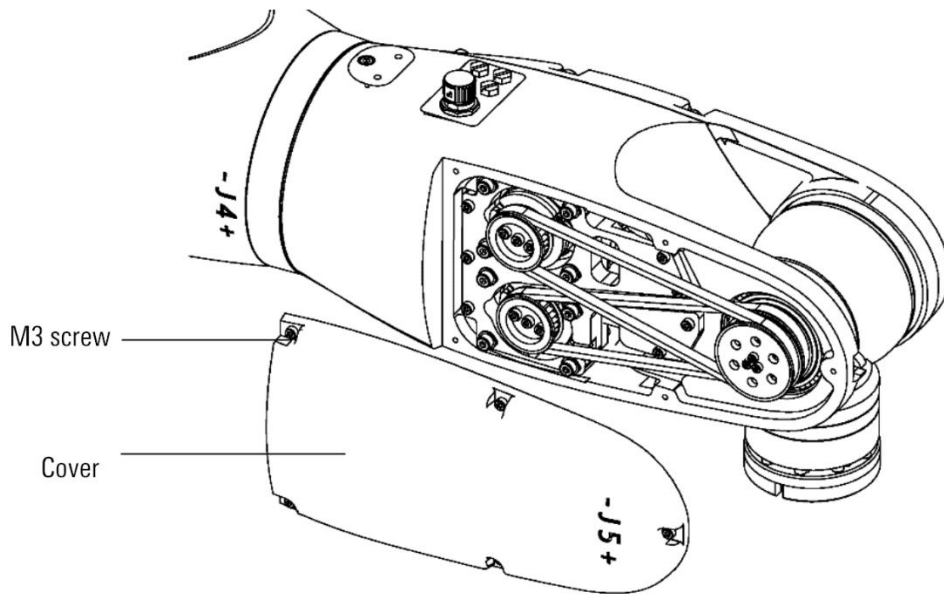

Figure 9-5 Remove the cover

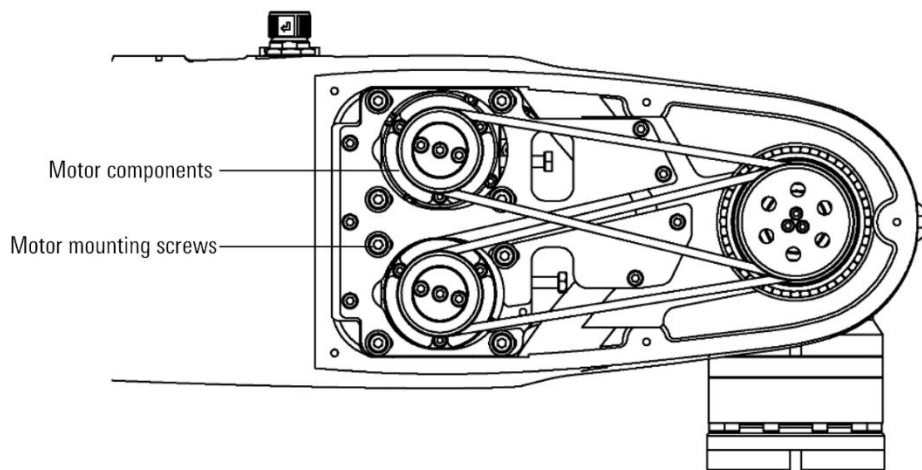

Figure 9-6 Remove the timing belt

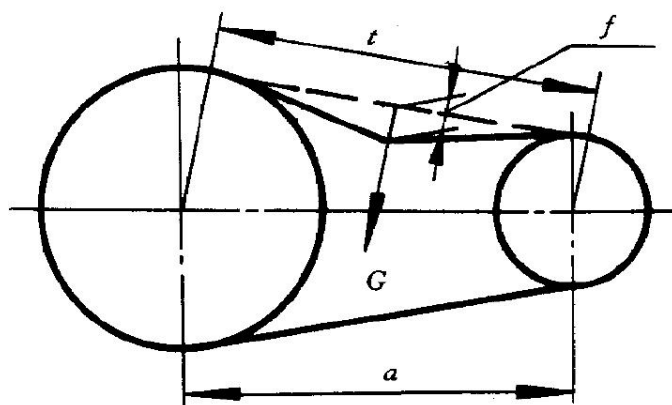

Figure 9-7 Synchronous belt installation deflection



Warning

After replacing the timing belt, perform the calibration of the J5 and J6 axis of the manipulator. For details, please refer to Chapter 6 of this manual.

## 10 Fault finding, diagnosis and repSOT

The malfunction of the manipulator is sometimes caused by multiple different reasons. It is often difficult to thoroughly investigate the cause. If the error handling method is adopted, the malfunction may be further deteriorated. Therefore, it is very important to analyze the malfunction in detail and find the real cause.

The possible faults and causes of the manipulator are shown in Table 10- 1. If you are not sure of the cause or how to deal with it, please contact our company.

Table 10- 1 Possible faults and causes of manipulator

Fault	Classification	Possible Causes	Treatment
Vibration Abnormal noise	<ul style="list-style-type: none"> <li>■ When the manipulator operates, its base floats from the workshop pedestal</li> <li>■ There is a gap between the base and workshop pedestal</li> <li>■ The screws connecting the base and workshop pedestal are loose</li> </ul>	<ul style="list-style-type: none"> <li>■ Fixation of Base:</li> <li>■ The manipulator base is not firmly fixed on the workshop pedestal</li> <li>■ The base floats from the workshop pedestal and generates the vibration when the manipulator acts due to the screw looseness, insufficient flatness of base and the foreign objects.</li> </ul>	<ul style="list-style-type: none"> <li>■ When the screw is loose, tighten it with the torque wrench according to the proper torque</li> <li>■ Trim the base flatness in accordance with the tolerance</li> <li>■ Check if the foreign matters are trapped, and if so, remove them</li> <li>■ Please consult with us</li> </ul>
	Workshop pedestal vibrates when the manipulator acts	<p>Workshop Pedestal:</p> <ul style="list-style-type: none"> <li>■ Pedestal is not completely fixed on the foundation. Therefore, the workshop pedestal vibrates when the manipulator acts.</li> <li>■ The insufficient rigidity of workshop pedestal, and the reaction force and torque generated by the manipulator cause the deformation and vibration.</li> </ul>	<ul style="list-style-type: none"> <li>■ Completely fix the workshop pedestal according to the corresponding method</li> <li>■ Workshop pedestal shall be processed to improve its rigidity</li> <li>■ For the workshop pedestal with machining difficulty, the vibration may be mitigated through the modification of moving program</li> <li>■ Please consult with us</li> </ul>
Vibration Abnormal noise	<ul style="list-style-type: none"> <li>■ Vibration at a specific posture during the action</li> <li>■ No vibration at the slow action</li> <li>■ Obvious vibration during acceleration and deceleration</li> <li>■ Simultaneous vibration of multiple axes</li> </ul>	<ul style="list-style-type: none"> <li>■ Vibration may occur because the load of the manipulator exceeds the allowable value</li> <li>■ Vibration may be caused because the action program is too strict on the manipulator</li> <li>■ Vibration may occur due to improper acceleration</li> </ul>	<ul style="list-style-type: none"> <li>■ Confirm whether the load of the manipulator exceeds the allowable value, reduce the load or change the action program</li> <li>■ Can reduce the speed, reduce the acceleration, change the action program, alleviate the vibration of the specific part</li> </ul>



Fault	Classification	Possible Causes	Treatment
	<ul style="list-style-type: none"> <li>■ Collision or long-term overload operation of manipulator</li> <li>■ No replacement of lubricating grease for a long time</li> </ul>	<ul style="list-style-type: none"> <li>■ Mechanical transmission system is subjected to excessive external force due to collision or overload, causing the damage to the gear surface or rolling surface of the gear, bearing, reducer or the peeling due to fatigue</li> <li>■ The gear surfaces or rolling surfaces of gear, bearing and reducer are damaged due to the foreign matters trapped in the gear, bearing or reducer.</li> <li>■ The gear surfaces or rolling surfaces of gear, bearing and reducer peel off due to fatigue because of no replacement of lubricating grease for long term</li> <li>■ The above reasons may cause the periodic vibration or abnormal noise</li> </ul>	<ul style="list-style-type: none"> <li>■ Make the manipulator operate uniaxially to confirm the Joint that produces the vibration and noise</li> <li>■ If you need to replace the gear, bearing and reducer, please contact us.</li> <li>■ Do not use the manipulator at overloaded status</li> <li>■ If you need to replace the lubricating grease, please contact us.</li> <li>■ Please consult with us</li> </ul>
<p>Vibration Abnormal noise</p>	<p>Causes may not be determined mechanically</p>	<ul style="list-style-type: none"> <li>■ Fault of the circuit inside the controller, failure of command to transmit to the motor, or the motor information not correctly transmitted to the controller</li> <li>■ Fault of pulse encoder and the position of motor not correctly transmitted to the controller</li> <li>■ Failure of motor body to perform its original functions</li> <li>■ Breakage of internal motor cable of manipulator causes the command not to be correctly transmitted to the motor and control system</li> <li>■ Voltage drop and no guarantee for the specified voltage</li> <li>■ Incorrect control parameters are input</li> </ul>	<ul style="list-style-type: none"> <li>■ For the fault of controller, see the controller manual</li> <li>■ Replace the motor of vibrating Joint to confirm whether it vibrates</li> <li>■ Check the cables of the manipulator body, between the manipulator body and control cabinet, and inside the controller for damage, and if so, replace the cable.</li> <li>■ Check whether the cable joint is in good contact. In case of the poor contact or looseness, re-tighten or take appropriate measures to ensure the good contact.</li> <li>■ Check whether the action control parameters are correct, and if not, re-enter the correct parameters.</li> <li>■ Please consult with us</li> </ul>

Fault	Classification	Possible Causes	Treatment
	<p>The mechanical action near the manipulator is closely related to the vibration of robot.</p>	<ul style="list-style-type: none"> <li>■ Mechanical electrical noise from the manipulator</li> <li>■ If the grounding wire is not connected properly, the electrical noise will mix into the grounding wire, causing the vibration of manipulator due to the interference with command</li> <li>■ Poor connection of grounding wire will lead to the unstable grounding, causing the vibration of manipulator due to electrical noise interference.</li> </ul>	<ul style="list-style-type: none"> <li>■ Connect the grounding wire properly to avoid the electrical noise mixed into the manipulator</li> <li>■ Please consult with us</li> </ul>
<p>Vibration Abnormal noise</p>	<ul style="list-style-type: none"> <li>■ Abnormal noise after the replacement of lubricating grease</li> <li>■ Abnormal noise occurs during the operation of robot after a long-term shutdown</li> <li>■ Abnormal noise at low speed</li> </ul>	<p>Abnormal noise from the manipulator at low speed immediately after the replacement or at the restart after the long-term shutdown.</p>	<p>Observe the operation of manipulator for 1-2 days. Usually the abnormal noise will disappear.</p>
<p>Shake of manipulator</p>	<ul style="list-style-type: none"> <li>■ After power-off, some parts of manipulator may be shaken manually.</li> <li>■ There is a gap between the connecting surfaces of manipulator</li> </ul>	<ul style="list-style-type: none"> <li>■ Manipulator bolts are loose</li> <li>■ Connecting bolts on the manipulator are loose due to the overload, collision, etc., thus resulting in the shake</li> </ul>	<p>For each Joint, check if the bolts at the following parts are loose. If so, tighten it with a torque wrench according to a suitable torque.</p> <ul style="list-style-type: none"> <li>■ Fixing bolts of motor</li> <li>■ Fixing bolts of reducer shell</li> <li>■ Fixing bolts of output shaft of reducer</li> <li>■ Fixing bolts of pedestal</li> <li>■ Fixing bolts between arms</li> <li>■ Fixing bolts of shell</li> <li>■ Fixing bolts of end effector</li> </ul>
	<p>Turn off the power of manipulator, and confirm that the screws are tightened, and shake the entire head of manipulator manually</p>	<p>Large backlash is resulted from the wear or damage of internal gears of manipulator due to the overload, collision, etc.</p>	<p>If you need to replace the internal gear, please consult with us</p>
<p>Motor overheating</p>	<ul style="list-style-type: none"> <li>■ Ambient temperature rise for installation of manipulator, and the overheating of motor</li> <li>■ Motor overheats after the cover plate</li> </ul>	<p>Ambient Temperature :</p> <ul style="list-style-type: none"> <li>■ Ambient temperature rise or the deterioration of heat dissipation of motor after the cover plate is installed</li> </ul> <p>Load Action:</p>	<ul style="list-style-type: none"> <li>■ Decrease of ambient temperature may prevent the motor from overheating</li> <li>■ Improvement of ventilation conditions around the motor, i.e. the heat dissipation of motor, may effectively</li> </ul>

Fault	Classification	Possible Causes	Treatment
	<p>is mounted on the motor</p> <ul style="list-style-type: none"> <li>■ Motor overheats after the action procedures of manipulator and load conditions are changed</li> </ul>	<ul style="list-style-type: none"> <li>■ Current value of motor exceeds its rated value due to the load and operating procedures</li> </ul>	<p>prevent the motor from overheating.</p> <ul style="list-style-type: none"> <li>■ A radiation shielding plate if there is a heat source around the motor may prevent the motor from overheating.</li> <li>■ Slowing down the action procedures and reducing the load may decrease the average current value of motor, thus preventing the motor from overheating.</li> <li>■ Please consult with us</li> </ul>
	<p>Motor overheats after the action control parameters of manipulator are changed</p>	<p>Control Parameter: Improper input parameters will cause the incorrect acceleration and deceleration of robot, so that the average current value of increases.</p>	<ul style="list-style-type: none"> <li>■ Enter the appropriate parameters according to the relevant instructions.</li> <li>■ Please consult with us</li> </ul>
	<p>Motor overheats due to the causes other than above ones</p>	<p>Mechanical Fault of Manipulator: Mechanical system fault of manipulator causes the overload of motor</p> <p>Motor fault:</p> <ul style="list-style-type: none"> <li>■ Brake fault causes the motor to always operate when the brake is applied, which causes the motor to withstand excessive load</li> <li>■ Failure of motor body to perform its functions causes the excessive current to flow through the motor</li> </ul>	<ul style="list-style-type: none"> <li>■ Please rectify the mechanical fault by reference to the instructions of vibration, abnormal noise and looseness.</li> <li>■ Please confirm whether the brake is released when the motor is powered on.</li> <li>■ After the motor is replaced, the overheating of motor disappears. It is confirmed that the this condition is abnormal.</li> <li>■ Please consult with us</li> </ul>
<p>Leakage of lubricating grease</p>	<p>Lubricating grease leaks out from the mechanical part</p>	<p>Poor Sealing:</p> <ul style="list-style-type: none"> <li>■ Crack of casting due to the excessive external force caused by the collision</li> <li>■ Damage of O-ring during the disassembly and reassembly</li> <li>■ Scratch of oil seal due to the dust intrusion</li> <li>■ Poor sealing between the cover plate and casting</li> </ul>	<ul style="list-style-type: none"> <li>■ In case of casting crack, etc., the sealant may be used to block the lubricating grease as an emergency measure, but in view of the further extension of crack, the part shall be replaced as soon as possible.</li> <li>■ Please consult with us</li> </ul>

Fault	Classification	Possible Causes	Treatment
Falling of manipulator Joint	<ul style="list-style-type: none"> <li>■ The brake is completely ineffective and the Joint falls quickly</li> <li>■ After the brake is contracted, the shaft falls slowly</li> </ul>	<ul style="list-style-type: none"> <li>■ The damage of brake drive relay causes the brake to always be powered on and not to work.</li> <li>■ Wear and damage of brake body affect the braking effect.</li> <li>■ The lubricating oil and grease inside the motor cause the brake to slip.</li> </ul>	<ul style="list-style-type: none"> <li>■ Check if the brake drive relay is damaged, and if so, replace the relay</li> <li>■ In case of the wear of brake, the damage of brake body and the lubricating grease inside the motor, replace the motor.</li> <li>■ Please consult with us</li> </ul>
Position offset	<ul style="list-style-type: none"> <li>■ Manipulator deviates from the teaching position</li> <li>■ The repeated positioning accuracy of manipulator is greater than the allowed value</li> </ul>	<p>Mechanical Fault:</p> <ul style="list-style-type: none"> <li>■ The unstable repeated positioning accuracy may be caused by the mechanical system abnormality, screw looseness, etc.</li> <li>■ The repeated positioning accuracy keeps stable after the deviation; the joint surface of pedestal surface, Joint casting and reducer may slide due to the excessive load such as the collision.</li> <li>■ Abnormality of motor encoder</li> </ul>	<ul style="list-style-type: none"> <li>■ In case of the unstable repeated positioning accuracy, please rectify the mechanical fault by reference to the instructions for the vibration, abnormal noise and shaking.</li> <li>■ If the repeated positioning accuracy keeps stable, please modify the teaching program. If the collision does not occur again, the deviation may be avoided.</li> <li>■ In case of the abnormality of motor encoder, replace the motor or encoder.</li> <li>■ Please consult with us</li> </ul>
	Position only deviates from the specific peripheral equipment	<p><b>Deviation of Peripheral Equipment</b></p> <p>The external equipment under the external force leads to the deviation relative to the manipulator</p>	<ul style="list-style-type: none"> <li>■ Please relocate the peripheral equipment</li> <li>■ Please modify the teaching program</li> <li>■ Please consult with us</li> </ul>
	Deviation occurs after the modification of parameters	<p><b>Parameters:</b></p> <p>The modification of calibration data causes the loss of manipulator origin</p>	<ul style="list-style-type: none"> <li>■ Re-enter the previous correct calibration data</li> <li>■ In case of uncertain calibration data, please recalibrate the manipulator</li> <li>■ Please consult with us</li> </ul>



## Appendix A type manipulator regular maintenance table

Note: ○ means maintenance is required.

Appendix A Periodic Maintenance Schedule of Manipulator

Item	Mainten ance cycle	First Maintenan ce 320h	3 mont hs 960h	6 mont hs 1,920 h	9 mont hs 2,880 h	1 year 3,840 h	15 mont hs 4,800 h	18 mont hs 5,760 h	21 mont hs 6,720 h	2 year 7,680 h	27 mont hs 8,640 h	30 mont hs 9,600 h	33 month s 10,56 0h	3 year 11,52 0h	39 month s 12,48 0h	42 month s 13,44 0h	45 month s 14,40 0h	4 year 15,36 0h	51 month s 16,32 0h	54 month s 17,28 0h	57 month s 18,24 0h	5 year 19,20 0h
Cleaning of manipulator	0.5h	○	○	○	○	○	○	○	○	○	○	○	○	○	○	○	○	○	○	○	○	○
Cleaning of control cabinet vent	0.1h	○	○	○	○	○	○	○	○	○	○	○	○	○	○	○	○	○	○	○	○	○
Wether the synchronous belt worn	0.5h	○		○	○	○		○		○		○		○		○		○		○		○
Check the manipulator cable for damage	3h	○		○	○	○		○		○		○		○		○		○		○		○
Check the manipulator cable sheath for damage	2h	○		○	○	○		○		○		○		○		○		○		○		○
Check the connecting cable of teach pendant,	0.2h	○			○	○				○				○				○				○

control cabinet and manipulator for damage																						
Check the connectors of motor, etc. for looseness	0.2h	○			○	○				○				○								○
Tighten the end effector screws	0.2h	○			○	○				○				○								○
Tighten the external main screws	1h	○			○	○				○				○								○
Check the end effector cable for damage	0.2h	○			○	○				○				○								○
Check the limit rubber block for damage	0.1h	○			○	○				○				○								○
Replacement of Synchronous Belt	1h					○				○				○								○
Battery Replacement	0.5h									○												○
Replace the internal	8h																					○

cables of manipulator																						
Manipulator overhaul																						○





## Appendix B Table of screw strength and tightening torque (Nm)

Appendix B Table of screw strength and tightening torque (Nm)

Thread specification \ Performance level	8.8 level	10.9 level	12.9 level
M2	0.35	0.48	0.56
M2.5	0.68	0.93	1.1
M3	1.2	1.6	2
M4	2.8	3.7	4.4
M5	5.6	7.5	9
M6	9.5	12.5	15
M8	23	31	36
M10	45	60	70
M12	78	104	125
M14	113	165	195
M16	195	250	305
M20	370	500	600



Prompt

- All screws must be tightened with proper torque.
- Except for the torque specified in the text, the corresponding tightening torque shall be selected according to the screw performance level.
- Remove foreign matters in screws and threaded holes.
- Torque for lightly lubricated screws.
- Screws shall be tightened evenly and symmetrically.
- According to the installation requirements of the reducer and other moving parts, apply thread adhesive to the engagement part of some screws.

**ligent** | LIGENT TECH CO., LTD



Website



YouTube

Official Website: <http://ligentrobot.com>  
E-Mail: [info@sotrobot.com](mailto:info@sotrobot.com)  
whatsapp:+86-13551010933

The introduction of the products is only for reference, the products and services delivered shall be subject to the specific contract.